



WEIL-McLAIN

Beckett Model NX Burners

Ultra Oil

Oil Fired Water Boiler

Instruction Manual



⚠️ WARNING

Potential for Fire, Smoke and Asphyxiation Hazards



Incorrect installation, adjustment, or misuse of this burner could result in death, severe personal injury, or substantial property damage.

To the Homeowner or Equipment Owner:
Please read and carefully follow all instructions provided in this manual regarding your responsibilities in caring for your heating equipment.
Contact a professional, qualified service agency for installation, start-up or service work.
Save this manual for future reference.

To the Professional, Qualified Installer or Service Agency:
Please read and carefully follow all instructions provided in this manual before installing, starting, or servicing this burner or heating system.
The Installation must be made in accordance with all state and local codes having jurisdiction.

To the Owner:

Thank you for purchasing a Beckett burner for use with your heating appliance. Please pay attention to the Safety Warnings contained within this instruction manual. Keep this manual for your records and provide it to your qualified service agency for use in professionally setting up and maintaining your oil burner.

Your Beckett burner will provide years of efficient operation if it is professionally installed and maintained by a qualified service technician. If at any time the burner does not appear to be operating properly, **immediately contact your qualified service agency** for consultation.

We recommend annual inspection/service of your oil heating system by a qualified service agency.

Daily – Check the room in which your burner/appliance is installed. Make sure:

- Air ventilation openings are clean and unobstructed
- Nothing is blocking burner inlet air openings
- No combustible materials are stored near the heating appliance
- There are no signs of oil or water leaking around the burner or appliance

Weekly

- Check your oil tank level. Always keep your oil tank full, especially during the summer, in order to prevent condensation of moisture on the inside surface of the tank.

Contents

General Information	4
Hazard Definitions	4
▼ Remainder of manual to be used ONLY BY QUALIFIED SERVICE TECHNICIANS ▼	
Weil-McLain Burner Specifications	5
NX Burner Specifications for Weil-McLain Ultra Oil Boilers	5
General Information	6
Notice Special Requirements	6
Inspect/Prepare Installation Site	6
Clearances to Burner and Appliance	6
Inspect Chimney or Direct Vent System	6
Combustion Air Supply Information	7
Safety Shutoff for Direct Vent System	8
Direct/Sidewall Venting Application	8
Mounting dimensions	8
Installing the Oil Tank and Supply System	9
Fuel Line Valves and Filter	9
Fuel supply level with or above burner	9
Wiring Connections Diagram	10
Burner Control	12
Sequence of Operation - GeniSys 7505	12
Start the Burner and Set Combustion	15
Start-up and Initial Settings	15
Set Combustion with Test Instruments	15
Cover Installation	17
Trained Service Technician's Regular Maintenance 17	
Removing Nozzle Line for Service	18
(Reference the Replacement Parts Diagram.)	18
Nozzle Installation	18
Check/Adjust Electrodes	19
Check Retention Head Alignment and Cad Cell Sighting	20
Check/Adjust "Zero" Calibration	20
Blower Wheel Replacement	20
Shutting the Burner Off	20
Replacement Parts	22

General Information

Hazard Definitions

DANGER Indicates a hazardous situation, which, if not avoided, will result in death or serious injury.

WARNING Indicates a hazardous situation, which, if not avoided, could result in death or serious injury.

CAUTION Indicates a hazardous situation, which, if not avoided, could result in minor or moderate injury.

Within the boundaries of the hazard warning, there will be information presented describing consequences if the warning is not heeded and instructions on how to avoid the hazard.

NOTICE Intended to bring special attention to information, but not related to personal injury or property damage.

CAUTION **Frozen Plumbing and Water Damage Hazard**

If the residence is unattended in severely cold weather, burner primary control safety lockout, heating system component failures, power outages or other electrical system failures could result in frozen plumbing and water damage in a matter of hours. For protection, take preventive actions such as having a security system installed that operates during power outages, senses low temperature and initiates an effective action. Consult with your heating contractor or a home security agency.

WARNING **Owner's Responsibility**



Incorrect installation, adjustment, and use of this burner could result in severe personal injury, death, or substantial property damage from fire, carbon monoxide poisoning, soot or explosion.

Contact a professional, qualified service agency for the installation, adjustment and service of your oil heating system. This work requires technical training, trade experience, licensing or certification in some states and the proper use of special combustion test instruments.

Please carefully read and comply with the following instructions:

- Never store or use gasoline or other flammable liquids or vapors near this burner or appliance.
- Never attempt to burn garbage or refuse in this appliance.
- Never attempt to light the burner/appliance by throwing burning material into the appliance.
- Never attempt to burn any fuel not specified and approved for use in this burner.
- Never restrict the air inlet openings to the burner or the combustion air ventilation openings in the room.

WARNING **Professional Service Required**



Incorrect installation, adjustment, and use of this burner could result in severe personal injury, death, or substantial property damage from fire, carbon monoxide poisoning, soot or explosion.

Please read and understand the manual supplied with this equipment. This equipment must be installed, adjusted and put into operation only by a qualified individual or service agency that is:

- Licensed or certified to install and provide technical service to oil heating systems.
- Experienced with all applicable codes, standards and ordinances.
- Responsible for the correct installation and commission of this equipment.
- Skilled in the adjustment of oil burners using combustion test instruments.

The installation must strictly comply with all applicable codes, authorities having jurisdiction and the latest revision of the National Fire Protection Association Standard for the installation of Oil-burning Equipment, NFPA 31 (or CSA-B139 and CSA-B140 in Canada). Regulation by these authorities take precedence over the general instructions provided in this installation manual.

Weil-McLain Burner Specifications

NOTICE Frozen Plumbing and Water Damage Hazard.

Unoccupied residences in severely cold weather could experience frozen plumbing in just a few hours if the heating system fails for any reason. Consult your HVAC contractor for effective preventive protection, such as electronic monitoring systems with 24/7 dial-up

NX Burner Specifications for Weil-McLain Ultra Oil Boilers

The table below provides burner specifications and starting air settings for NX burners applied to Weil-McLain Model UO boilers. Follow all instructions in this burner manual, the boiler manual and the fuel pump literature to install, setup and service the burner.

NOTICE The remainder of this manual contains information to be used **ONLY** by a qualified Service Technician.

Table 1. Burner Configurations - Verify that burner specification number (on burner carton) and configuration agrees with information below.

Boiler Model	Burner Spec	Firing Rate (GPH)	Air Tube Combination	Insertion	Primary Nozzle	Alternate Nozzle	Fuel Pump Pressure (psig)	Head/Air Adjustment Plate Setting
UO-3 CV	WL6403 (See Note 1)	0.80	NX70LC	1-3/4"	0.65 X 60°A Delavan	0.65 X 70°B Hago	150	1.75
UO-3 CV	WL6403	1.00	NX70LC	1-3/4"	0.75 X 60°B Hago	0.75 X 60°B Delavan	175	2.50
UO-4 CV	WL6404	1.20	NX90LB	3-1/2"	1.00 X 70°B Hago	1.00 X 70°B Delavan	140	4.00
UO-5 CV	WL6405	1.40	NX90LD	3-1/2"	1.10 X 70°B Hago	1.10 X 70°B Delavan	160	1.50
UO-3 DV	WL6503 (See Notes 1 & 2)	0.80	NX70LC	1-3/4"	0.65 X 60°A Delavan	0.65 X 70°B Hago	150	1.75
UO-3 DV	WL6503 (See Note 2)	1.00	NX70LC	1-3/4"	0.75 X 60°B Hago	0.75 X 60°B Delavan	175	2.50
UO-4 DV	WL6504 (See Note 2)	1.20	NX90LB	3-1/2"	0.85 X 60°W Delavan	0.85 X 60°W Hago	190	4.00
UO-5 DV	WL6505 (See Note 2)	1.40	NX90LD	3-1/2"	1.10 X 70°B Hago	1.10 X 70°B Delavan	160	1.50

- 1) Shipped as 1.0 GPH Burner Configuration. The 0.80 GPH input uses same burner as 1.0 GPH input. Replace nozzle, adjust pump pressure and Head/Air setting as shown above and install 14"x16" blanket on combustion chamber floor. (See Maintenance Section for Nozzle Replacement details.)
- 2) Direct Vent Boilers require that a combustion chamber blanket be installed (blanket supplied with burner).

Figure 1. Burner label location

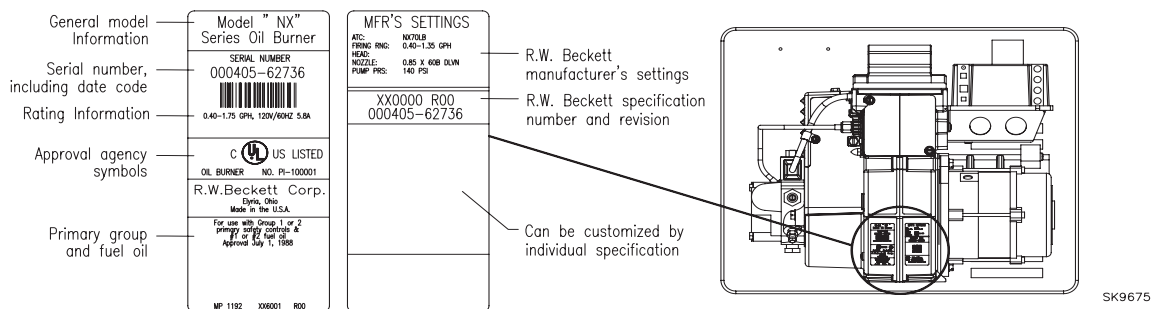

General Information

Table 2. – Burner Specifications

Capacity LB & LC	Firing rate: 0.40 – 1.35 GPH Input: 56,000 – 189,000 Btu
Capacity LD & LF	Firing rate: 1.10 - 1.75 GPH Input: 154,000 – 245,000 Btu/h
Fuels	<p>U. S. No. 1 or No. 2 heating oil only (ASTM D396) Canada No. 1 stove oil or No. 2 furnace oil only</p> <div style="text-align: center;">  <p>DO NOT USE GASOLINE, CRANKCASE OIL, OR ANY OIL CONTAINING GASOLINE.</p> </div>
Electrical	<p>Power supply: 120 VAC, 60 Hz, single phase Operating load: 5.8 Amps max Motor: 1/7 hp, 3450 rpm, NEMA 48M frame PSC rotation CCW when facing shaft end Ignition: Continuous duty solid-state igniter</p>
Fuel pump	Outlet pressure - See Note 1
Air tube	ATC code - See Table 3
Dimensions (with cover)	<p>Height (maximum): 12-1/2 inches Width (maximum): .15 inches Depth: 9-1/4 inches Air tube diameter: 3-1/4 inches</p>

*Note 1. See appliance manufacturer's burner specifications for recommended outlet pressure.

Table 3. – Air Tube Combinations (ATC)

Firing rate (gph)	Head	ATC codes for usable air tube lengths:		
		5"	7"	9"
0.40-1.35	9-Slot	NX50LB	NX70LB	NX90LB
0.40-1.35	6-Slot	NX50LC	NX70LC	NX90LC
1.10-1.75	9-Slot	NX50LD	NX70LD	NX90LD
1.10-1.75	6-Slot	NX50LF	NX70LF	NX90LF

Notice Special Requirements

- THE INSTALLATION OF A BURNER SHALL BE IN ACCORDANCE WITH THE REGULATIONS OF AUTHORITIES HAVING JURISDICTION.
- For recommended installation practices in the U.S. refer to the latest edition of NFPA 31. (CSA-B139 and CSA-B140 in Canada).
- Concealed damage — If you discover damage to the burner or controls during unpacking, notify the carrier at once and file the appropriate claim.
- When contacting Beckett for service information — Please record the burner serial number (and have available when calling or writing). You will find the serial number on the silver label located on the left rear of the burner. Refer to Figure 1.

Certifications/approvals

Underwriters Laboratories has certified this burner to comply with ANSI/UL 296 and CSA-B139. *Low sulfur #1 and #2 fuel oils reduce heat exchanger deposits with all burners compared to the standard fuels. Reduced deposits extend the service interval for cleaning and improve the efficiency of the appliance over time. Low sulfur fuels reduce particulate and oxides of nitrogen emissions as well. The Oilheat Manufacturers' Association recommends these fuels as the preferred fuels for this burner.*

Inspect/Prepare Installation Site

Clearances to Burner and Appliance

Provide space around burner and appliance for ease of service and maintenance. Check the minimum clearances against those shown by the appliance manufacturer and by applicable building codes.

Inspect Chimney or Direct Vent System

Fire, Smoke & Asphyxiation Hazard

- Carefully inspect the chimney or exhaust vent system.
- Make sure it is properly sized and in good working condition.
- Follow the instructions supplied by the appliance manufacturer.
- The installation must strictly comply with all applicable codes, authorities having jurisdiction and the latest revision of the National Fire Protection Association Standard NFPA 31 for the installation of chimneys and vent sizing, (or CSA-B139 and CSA-B140 in Canada).
- Regulation by these authorities take precedence over the general instructions provided in this installation manual.

1. Starting with minimum gph firing rate, the minimum size recommended is 6" flue pipe with 8" X 8" inside chimney, unless specified otherwise by the appliance manufacturer.
2. A chimney flue shall extend at least 3 feet above the highest point at which the chimney comes in contact with the roof, and not less than 2 feet above the highest roof surface or structure within 10 feet horizontally of the chimney. Refer to Figure 2.

Figure 2 – Chimney Design - Above the Roof

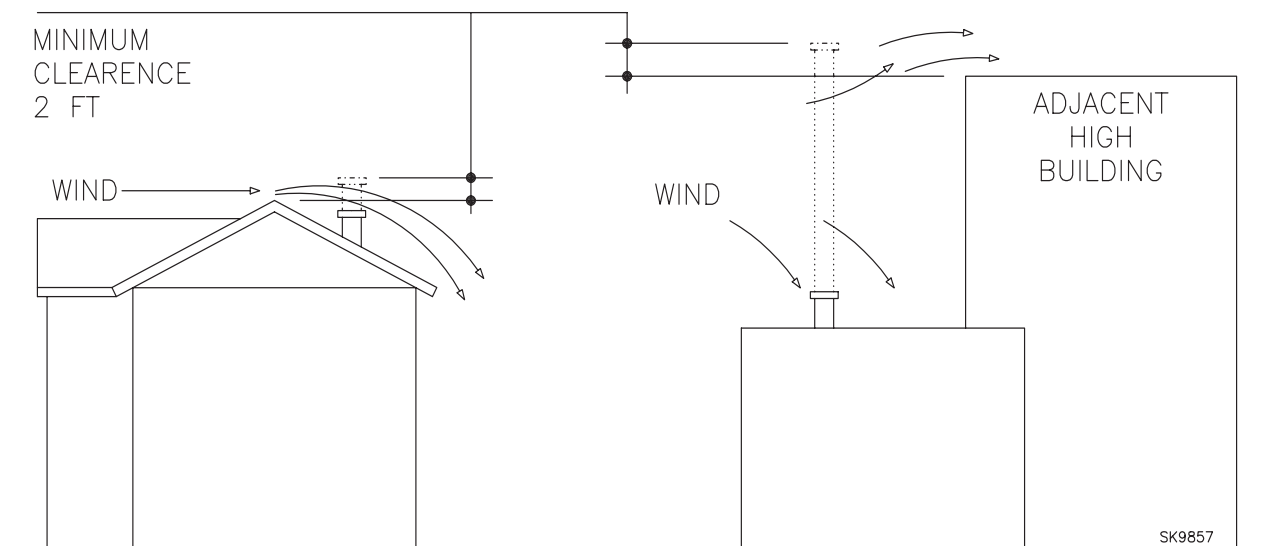

NOTE: Correct chimney design is shown by dotted lines. Incorrect chimney design, as shown by the solid lines, may result in down-drafts.

3. Any accumulation of soot or debris in chimney offsets should be removed
4. Any obstructions such as a protruding joint or a piece of broken tile wedged in the chimney should be removed.
5. No other appliance connection should be made to the same flue pipe.
6. The flue pipe should have an upward pitch toward the chimney of at least 1/4" per foot of length. It should fit tightly and should not project into the chimney.
7. Any leakage between tiles, around clean-out doors, or around the vent pipe should be sealed.

Insulated Stainless Steel Chimney Liners

The new designs of high efficiency oil furnaces and boilers in conjunction with flame retention oil burners are more efficient. One result of increased efficiency is lower flue gas temperatures. As flue gases rise in the chimney, they will cool and condense when they reach the dew point. The condensation will mix with the sulphur in the flue gases creating sulphuric acid. The acid will attack the chimney mortar, brick and clay liners causing corrosion, deterioration and blockage of the chimney. Eventually the blockage could prevent exhausting the flue gases. Instead, the flue gases could vent out the barometric damper into the living space. Therefore, it is strongly recommended that an approved insulated stainless steel liner be installed.

For those installations not requiring a chimney, such as through-the-wall vented appliances, follow the instructions given by the appliance and power venter (if used) manufacturers.

Combustion Air Supply Information



WARNING

Adequate Combustion and Ventilation Air Supply Required

Failure to provide adequate air supply could seriously affect the burner performance and result in damage to the equipment, asphyxiation, explosion or fire hazards.

- The burner cannot properly burn the fuel if it is not supplied with a reliable combustion air source.
- Follow the guidelines in the latest editions of the NFPA 31 and CSA-B139 regarding providing adequate air for combustion and ventilation.

See NFPA Standard 31 for complete details. **Appliances located in confined spaces:** All confined spaces should have two (2) permanent openings; one near the top of the enclosure and one near the bottom of the enclosure. Each opening must have a free area of not less than one (1) square inch per 1,000 BTU's per hour of the total input rating of all appliances within the enclosure. The openings should have free access to the building interior, which should have adequate infiltration from the outside.

Exhaust fans and other air-using devices: Size air openings large enough to supply all air-using devices in addition to the minimum size required for combustion air. If there is any possibility of the equipment room developing a negative pressure due to exhaust fans, clothes dryers, etc., either pipe combustion air directly to the burner or provide a sealed enclosure for the burner and supply it with its own combustion air supply.

Safety Shutoff for Direct Vent System

The direct vent blocked flue safety shut off system, refer to Figure 3, shuts down the burner if the exhaust flue is blocked and/or if the air inlet is blocked. It recognizes a blocked flue by sensing excessive pressure in the combustion chamber. It recognizes a blocked inlet by sensing excessive vacuum in the air inlet adapter. This system meets the requirements for a blocked flue or blocked combustion air inlet per CSA Standard B140.0. It is designed to interrupt the cad cell circuit and allow the control to shut down the burner.

Direct/Sidewall Venting Application

For direct vent installations, follow instructions provided with appliance and direct vent system. Outside combustion air is required for direct venting. When installing an NX outside air adapter (Beckett Part Number 52018U), refer to the instruction sheet supplied with the adapter. This kit allows combustion air to be

WARNING Follow the Outside Air Kit Instructions Exactly

Failure to comply could result in impaired combustion, appliance soot-up, puffback of smoke, and fire or asphyxiation hazards.

- Do not attempt to install outside air piping to the burner without using the outside air kit and instructions.

WARNING

Connect Outside Air Duct to NX Adapter



Failure to install adapter properly could result in impaired combustion, appliance soot-up, puffback of smoke, and fire or asphyxiation hazards.

- The outside air adapter must be installed by strictly following the kit installation instructions.
- DO NOT attempt to install outside air piping without using the outside air adapter and instructions provided.
- Abundant fresh air is required for proper combustion.

pipled directly to the burner. The NX outside air adapter kit may also be used for chimney vent applications that require outside combustion air.

Mounting dimensions

1. When using the Beckett universal adjustable flange, mount the air tube at a 2° downward pitch unless otherwise specified by the appliance manufacturer.
2. Verify that the air tube installed on the burner provides the correct insertion depth. See Figure 4.

Figure 4. – Mounting Burner in Appliance

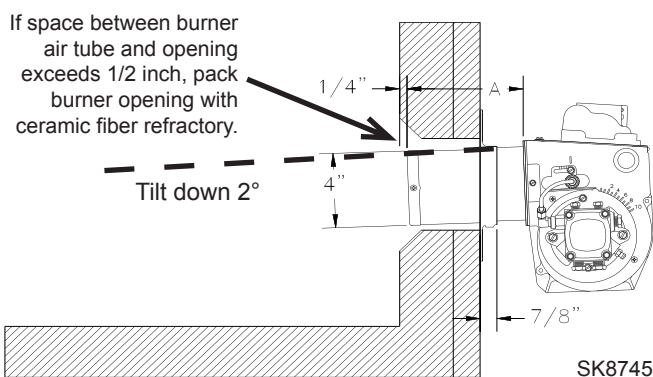
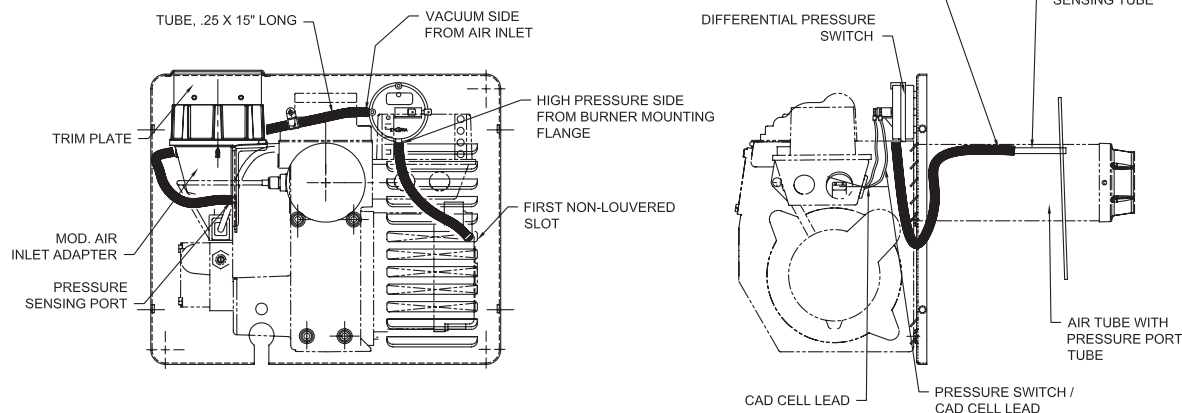

Figure 3. Pressure Switch Installation



- The end of the air tube should normally be $\frac{1}{4}$ " back from the inside wall of the combustion chamber. Never allow the leading edge of the head assembly to extend into the chamber, unless otherwise specified by the heating appliance manufacturer. Carefully measure the insertion depth when using an adjustable flange. Verify the insertion depth when using a welded flange.

Installing the Oil Tank and Supply System

WARNING Oil Leak and Fire Hazard

Install the oil tank following applicable standards in the U.S. by referring to the latest edition of NFPA 31 or CSA-B139 & CSA-B140 in Canada, and all authorities having jurisdiction.

CAUTION Do Not Use Teflon Tape

Damage to the pump could cause impaired burner operation, oil leakage and appliance soot-up.

- Never use Teflon tape on fuel oil fittings.
- Tape fragments can lodge in fuel line components and fuel unit, damaging the equipment and preventing proper operation.
- Use oil-resistant pipe sealant compounds.

Note: to determine the proper fuel line size, refer to the fuel pump manufacturer's instructions provided with the burner. Refer to Figure 5 or Figure 6 for typical installation layouts.

Fuel Line Valves and Filter

Install two high quality, oil duty rated, fusible handle design shutoff valves in accessible locations on the oil supply line. Locate one close to the tank and the other close to the burner, upstream of the filter for service access.

Install a generous capacity filter inside the building between the fuel tank shutoff valve and the burner, locating both the filter and the valve close to the burner for ease of servicing. Filter should be rated for 50 microns or less.

Fuel supply level with or above burner

WARNING Do Not Install By-pass Plug with 1-Pipe System

Failure to comply could cause immediate pump seal failure, pressurized oil leakage and the potential for a fire and injury hazard.

- The burner is shipped without the by-pass plug installed.
- Install the by-pass plug in two-pipe oil supply systems ONLY.

CAUTION Oil Supply Pressure Control Required

Damage to the filter or pump seals could cause oil leakage and a fire hazard.

- The oil supply inlet pressure to the burner **cannot exceed 3 psig**.
- Insure that a pressure limiting device is installed in accordance with the latest edition of NFPA 31.
- Do NOT install valves in the return line.**
- Gravity Feed Systems: Always install an anti-siphon valve in the oil supply line or a solenoid valve (RWB Part # 2182602U) in the pump/nozzle discharge tubing to provide backup oil flow cut-off protection.

The burner may be equipped with a single-stage fuel unit for these installations. Connect the fuel supply to the burner with a single supply line if you want a one-pipe system (making sure the bypass plug is NOT installed in the fuel unit.) Manual bleeding of the fuel unit is required on initial start-up. If connecting a two-pipe fuel supply, install the fuel unit bypass plug.

Figure 5. – Inside Tank Gravity Feed System

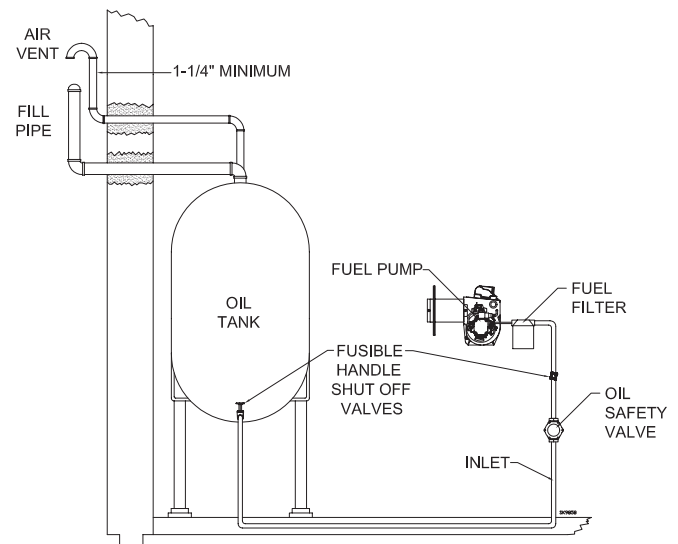
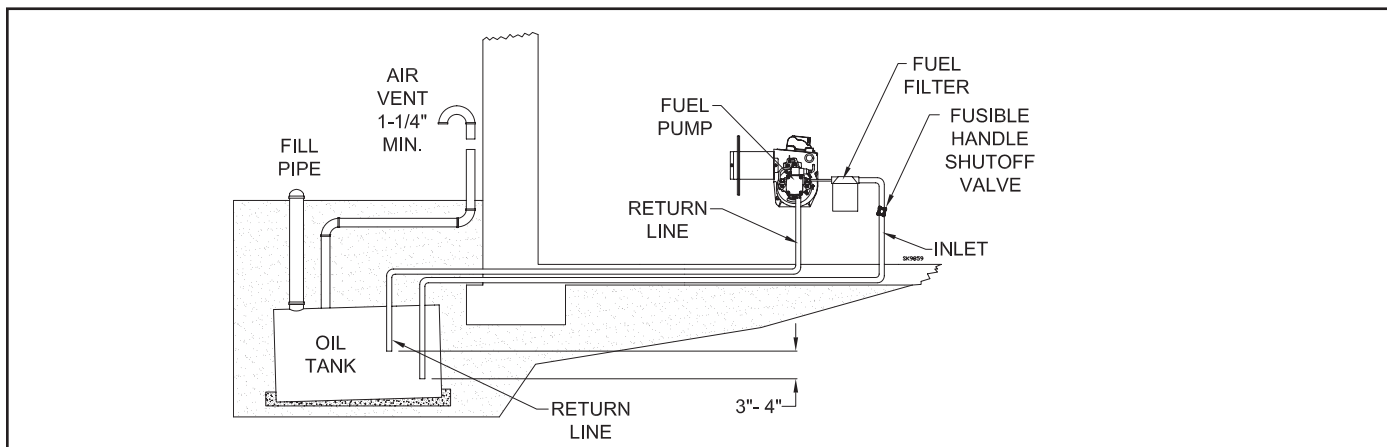

Figure 6. – Outside Buried Tank-Lift System



NOTICE To further protect the fuel supply system and reduce nozzle orifice plugging with firing rates below 0.75 gph, a dual filtration system can be installed. This typically consists of a 50 micron primary filter, located near the fuel tank and a secondary filter rated for at least 10 microns located near the burner.

Fuel supply below the level of the burner

When the fuel supply is more than eight feet below the level of the burner, a two-pipe fuel supply system is required. Depending on the fuel line diameter and horizontal and vertical length, the installation may also require a two-stage pump. Consult the fuel unit manufacturer’s literature, included with the burner, for lift and vacuum capability.

Fuel line installation

Continuous lengths of heavy wall copper tubing are recommended. **Always use flare fittings. Never use compression fittings.** Always install fittings in accessible locations. Proper routing of fuel lines is required to prevent air cavitation and vibration.

Wiring Connections Diagram

WARNING Electrical Shock Hazard



Electrical shock can cause severe personal injury or death.

- Disconnect electrical power before installing or servicing the burner.
- Provide ground wiring to the burner, metal control enclosures and accessories. (This may also be required to aid proper control system operation.)
- Perform all wiring in compliance with the National Electrical Code ANSI/NFPA 70 (Canada CSA C22.1)

CAUTION Incorrect Wiring Will Result in Improper Control Operation

- GeniSys wiring label colors may not match the wire colors of the burner or other manufacturers’ controls.
- The GeniSys Control should be wired according to the appliance manufacturer’s instructions.

- **Burner packaged with appliance** - Refer to appliance manufacturer’s wiring diagram for electrical connections.
- **Burner installed at jobsite** - Refer to Figures 7a and 7b, for typical burner wiring, showing cad cell primary controls. Burner wiring may vary, depending on primary control actually used. Refer to the appliance manufacturer’s wiring diagram prior to connecting the burner wiring. All wiring must be in accordance with the latest revision of national Electric Code NFPA 70 and all local codes and regulations. In Canada, all wiring is to be in accordance with the Canadian Electrical Code, Part 1.

Figure 7. – Burner Connections.

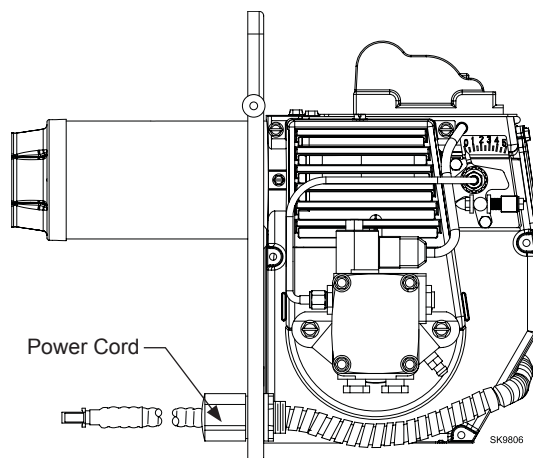

WARNING Explosion, Fire, Scald, and Burn Hazard



All heating appliances must have **HIGH LIMIT** protection to interrupt electrical power and shutdown the burner if operating or safety controls fail and cause a runaway condition.

- Follow the appliance manufacturer's wiring diagrams and note all required safety controls.
- Typical safety controls include high temperature or pressure limits, low water cutoffs, pressure relief valves and blocked flue sensing switches.
- Verify all limit and safety controls are installed and functioning correctly, as specified by the manufacturer, applicable safety standards, codes and all authorities having jurisdiction.
- Ensure that the appliance is free of oil and oil vapor before starting or resetting the burner.

Refer to the appliance manufacturer's wiring diagram prior to connecting the burner wiring. All wiring must be in accordance with the latest revision of National Electric Code NFPA 70 and all local codes and regulations.

NOTICE

The 7505 primary control with valve-on delay (pre-time) and burner motor-off delay (post-time) requires a constant 120 volts AC power source supplied to the BLACK wire on the control. The RED wire goes to the appliance limit circuit.

- Make connections to the control's terminals as shown in **Figures 7a** and **7b**. Refer to the label on the underside of the control for wiring details.

NOTICE

Motor-off delay on a 7505P will be disabled if the safety and operating limits as shown in Figures 7a and 7b interrupt power to the control terminal L1.

- Connect thermostat leads to the TR and TW terminals on the control or jumper the TR and TW terminals on the control, as directed by the appliance wiring diagram.
 - Thermostat anticipator Current: 0.1 amp
 - Thermostat voltage: 24 volts AC

NOTICE

If the thermostat short cycles or operates improperly, it may require an isolation relay for proper operation. The Beckett A/C Ready Kit (part no. 51950U) provides this function. Wiring instructions are included with the A/C Ready Kit.

Figure 7a. – GeniSys 7505 Control interrupted ignition, valve-on delay only (no motor-off delay)

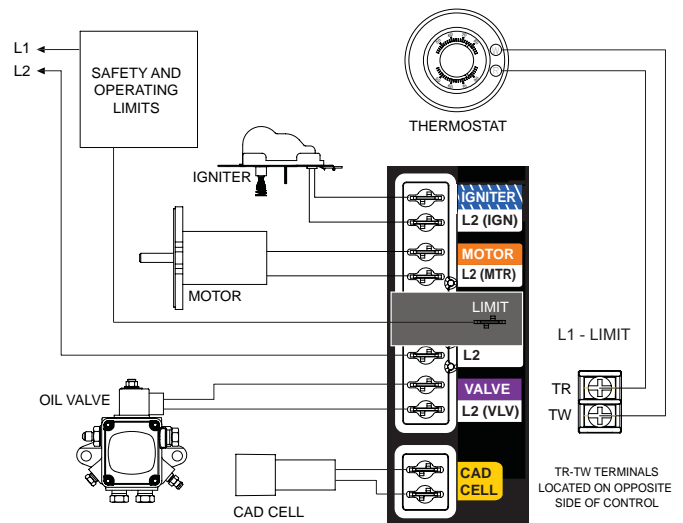
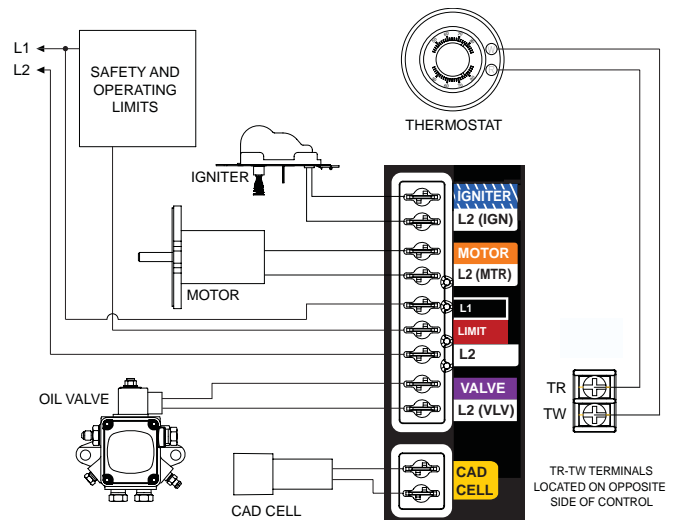

Figure 7b. – GeniSys 7505 Control Interrupted ignition, valve-on delay and motor-off delay



Burner Control

WARNING Fire or Explosion Hazard

Can cause severe injury, death, or property damage.

- The control can malfunction if it gets wet, leading to accumulation of oil or explosive oil vapors.
- Never install where water can flood, drip or condense on the control.
- Never use a control that has been wet - replace it.

Sequence of Operation - GeniSys 7505

Refer to the appliance manufacturer's wiring diagram for actual specifications.

- Standby:** The burner is idle, waiting for a call for heat.
- Valve-On Delay:** The igniter and motor are on while the control delays turning on the oil solenoid valve for the programmed time.
- Trial For Ignition:** The oil solenoid valve is energized. A flame should be established within the factory set trial for ignition time (lockout time).
- Lockout:** The control has shut down for one of the following safety reasons:
 - The trial for ignition (lockout) time expired without flame being established.
 - The cad cell detected flame at the end of the Valve On Delay state.

To reset the control from lockout click the button 1-second.

NOTE: A recurrence of the above failure modes or a failed welded relay check could cause the control to enter a **Hard Lockout** state that must be reset only by a qualified service technician.

To reset from Hard Lockout, hold the reset button for 15 seconds until the yellow light turns on.

- Ignition Carryover:** Once flame is established, the igniter remains on for 10 additional seconds to ensure flame stability.
- Run:** The flame is sustained until the call for heat is satisfied. The burner is then sent to Motor-Off Delay, if applicable, or it is shut down and sent to Standby.
- Recycle:** If the flame is lost while the burner is firing, the control shuts down the burner, enters a 60 second recycle delay,

and repeats the ignition sequence. The control will continue to Recycle each time the flame is lost, until it reaches a pre-set time allotment. The control will then go into Hard Lockout instead of recycle. This feature prevents excessive accumulation of oil in the appliance firing chamber.

- Motor-Off Delay:** If applicable, the oil solenoid valve is turned off and the control delays turning the motor off for the set motor-off delay time before the control returns to standby.
- Pump Prime:** The igniter and motor are on with the oil solenoid valve energized for 4 minutes. During Pump Prime mode, the cad cell is disregarded, allowing the technician to prime the pump without having to jumper the cad cell.
- Cad Cell Resistance Indicator:** If the Beckett 7505 control is equipped with the GeniSys Display Module, part 52067U, the cad cell resistance can be selected and read on the LCD screen. Also, the GeniSys Contractor Tool, part 52082U, can be used for this purpose.

If these are not available, the cad cell leads can be unplugged from the control and the resistance measured with a meter in the conventional way. Conduct these tests with flame present.

Flame Detection Range
Normal = 0 to 1600 ohms
Limited = 1600 ohms to lockout

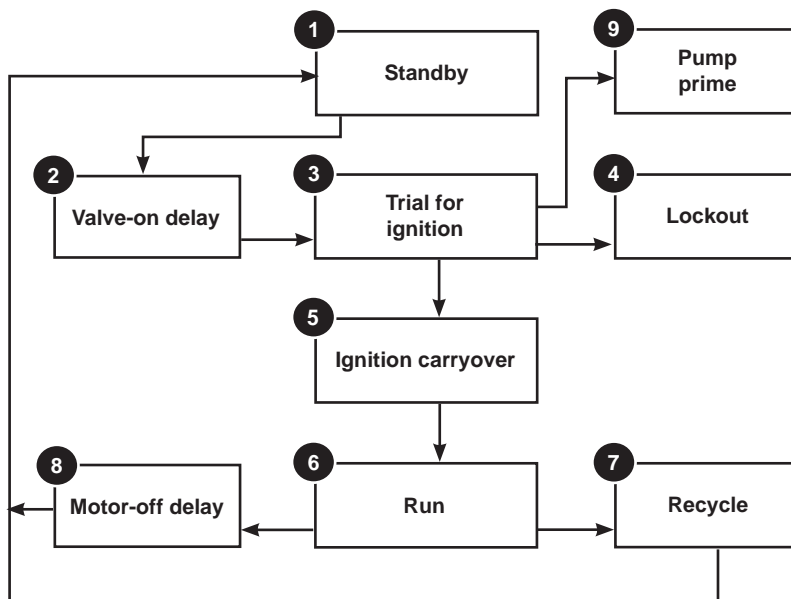
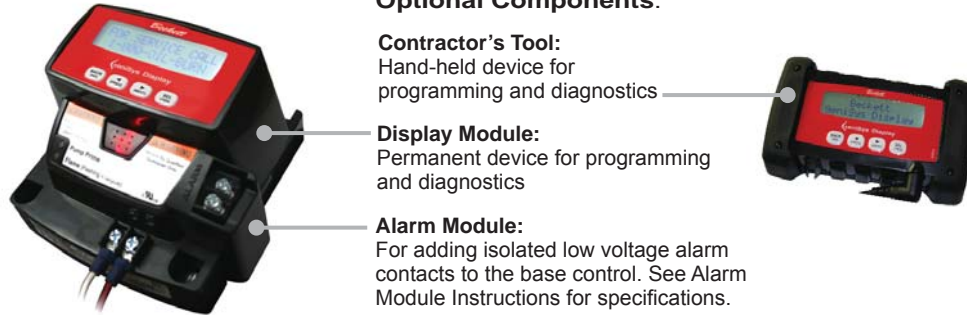

Figure 8. GeniSys Model 7505 Control



Optional Components:



Contractor's Tool:
Hand-held device for programming and diagnostics

Display Module:
Permanent device for programming and diagnostics

Alarm Module:
For adding isolated low voltage alarm contacts to the base control. See Alarm Module Instructions for specifications.

Reset Button Operation

The table below explains what action the control will take when the reset button is pressed for different lengths of time during the various burner operating states.

Table 4 - Reset Button Operation

If the burner is in the below state:	Pushing the reset button will:		
	Button Click (press < 1 second)	Button Hold (press > 1 second)	Button Hold (press 15+ seconds)
Lockout	Reset from Soft Lockout		Reset from Restricted (Hard) Lockout
Valve-on Delay, Trial for Ignition, Ignition Carryover	Go to Pump Prime (see "Priming the Pump" above)	Disable the Burner: Any time the burner is running, press and hold the reset button to disable the burner. The burner will remain off as long as the button is held.	Enables Pump Priming: After the reset button has been held for 15 seconds, the button can then be clicked during the next ignition sequence to enter Pump Prime mode.
Run (igniter is shut off)	No action		
Motor-Off Delay, Standby	No action		
Pump Prime	No action	Exit Pump Prime mode and return to Standby	

Table 5 - Status Lights

Light Color	On Continuously	Flashing
Red	Restricted (Hard) Lockout	Soft Lockout
Green	Flame Sensed during normal operation (Could be stray light during standby)	Recycle
Yellow	Control is in Pump Prime mode or Reset button currently held for 15+ seconds.	N/A

Figure 9. Typical Burner Wiring & Burner Sequence of Operation for R7184P Control.

Refer to the appliance manufacturer's wiring diagram for actual specifications.

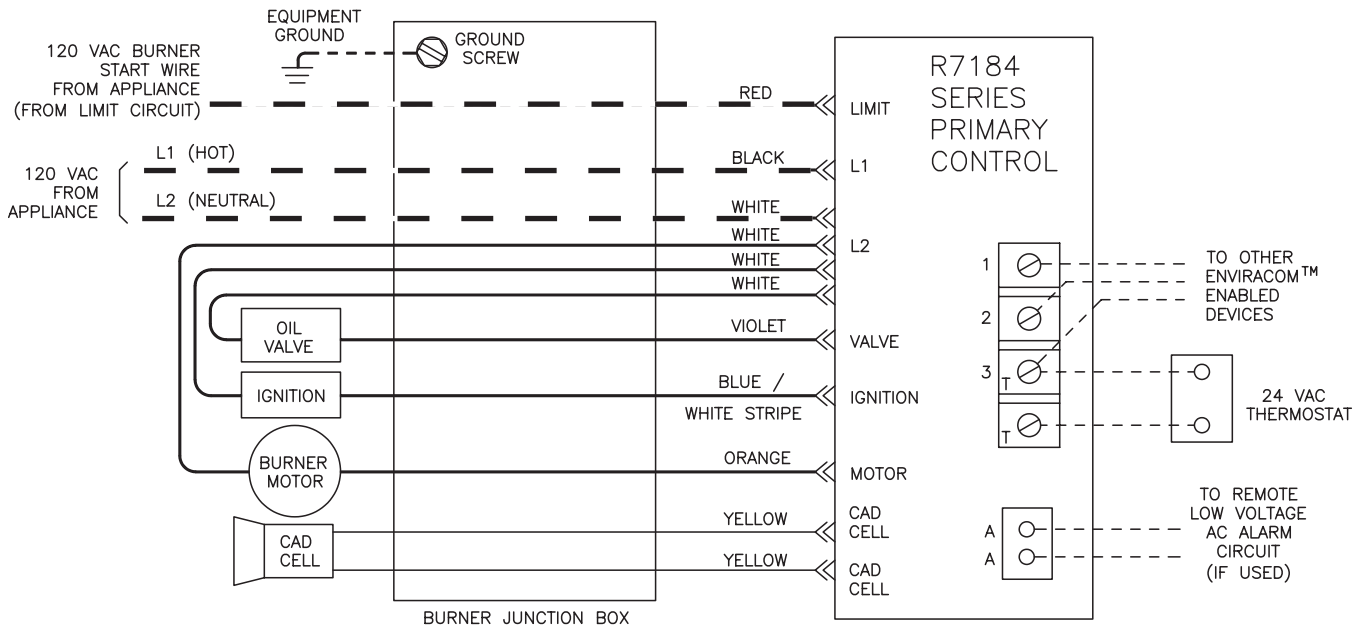

SK9359

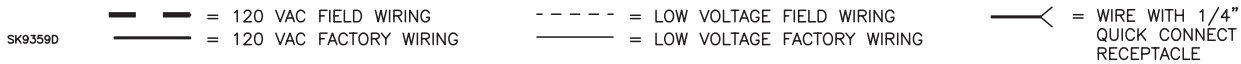

1. **STANDBY.** The burner is idle, waiting for a call for heat. When a call for heat is initiated, there is a 3-10 second delay while the control performs a safe start check.
2. **VALVE-ON DELAY.** The ignition and motor are turned on for a 15 second valve-on delay.
3. **TRIAL FOR IGNITION (TFI).** The fuel valve is opened. A flame should be established within the 15 second lockout time.
4. **LOCKOUT.** If flame is not sensed by the end of the TFI, the control shuts down on safety lockout and must be manually reset. If the control locks out three times in a row, the control enters restricted lockout.
5. **IGNITION CARRYOVER.** Once flame is established, the ignition remains on for 10 seconds to ensure flame stability before turning off. If the control is wired for intermittent duty ignition, the ignition unit stays on the entire time the motor is running.
6. **RUN.** The burner runs until the call for heat is satisfied. The burner is then sent to burner motor off delay, if applicable, or it is shut down and sent to standby.
7. **RECYCLE.** If the flame is lost while the burner is

firing, the control shuts down the burner, enters a 60 second recycle delay, and then repeats the above ignition sequence. If flame is lost three times in a row, the control locks out to prevent cycling with repetitious flame loss due to poor combustion.

8. **BURNER MOTOR-OFF DELAY.** The fuel valve is closed and the burner motor is kept on for the selected motor-off delay time before the control returns the burner to standby.

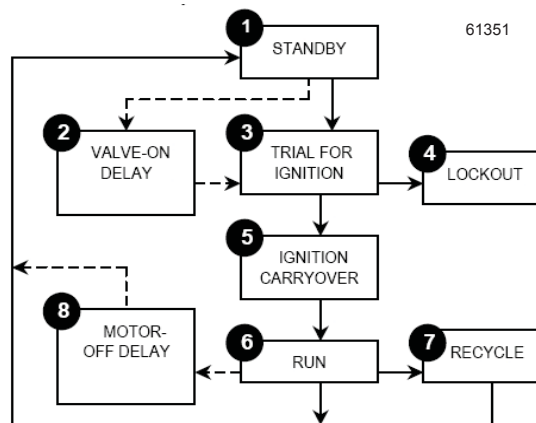

Control System Features

Feature	Interrupted ignition	Limited reset, Limited recycle	Diagnostic LED, cad cell indicator	Valve-on delay	Burner motor off delay	Alarm Contacts
R7184A	YES	YES	YES	—	—	—
R7184B	YES	YES	YES	YES	—	—
R7184P	YES	YES	YES	YES	YES	Optional

Start the Burner and Set Combustion

Start-up and Initial Settings

1. Open the shutoff valves in the oil supply line to the burner.
2. Referencing Figure 9, verify and/or set the Head/Air Adjustment Pointer to the value specified by the Appliance Manufacturer. Refer to Table 1. (***This is an initial air setting for the pump bleeding procedure only.***) Calibrated test instruments must be used for the final head/air adjustment.
3. Adjust the thermostat or temperature controller to call for heat. (*Note: return controller(s) to the original settings upon completion of burner installation or service.*)
4. Close the line voltage switch to start the burner. If the burner does not start within the 3 to 10 second safety start check timing, you may have to reset the safety switch on the burner primary control.
5. Bleed the air from the fuel pump as soon as the burner motor begins rotating.
6. Prepare for combustion tests by drilling a 1/4" sampling hole in the flue pipe between the appliance and the barometric draft regulator. Seal this hole when testing is complete. (See appliance manufacturer's instructions for location.)
7. Check/Adjust the Zero Calibration for the Head/Air Adjustment Mechanism. Refer to Figure 9.
 - a. Slightly loosen the zero setting locking nut.
 - b. Turn the adjustment screw until the reading is set to zero. (Mid-point of pointer should line up with zero.
 - c. Turn the adjustment screw counterclockwise to adjust the plate with the pointer to the zero position.

Figure 9. Head/air Adjustment Plate Assembly

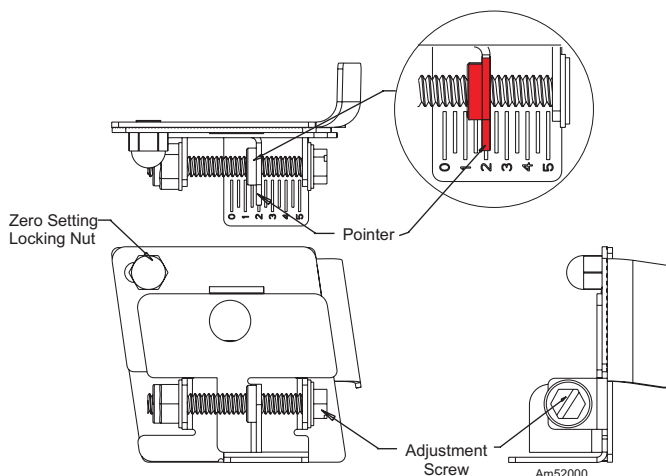

WARNING Explosion and Fire Hazard



Failure to follow these instructions could lead to equipment malfunction and result in heavy smoke emission, soot-up, hot gas puff-back, fire and asphyxiation hazards.

- Do not attempt to start the burner when excess oil has accumulated in the appliance, the appliance is full of vapor, or when the combustion chamber is very hot.
- Do not attempt to re-establish flame with the burner running if the flame becomes extinguished during start-up, venting, or adjustment.
- **Vapor-Filled Appliance:** Allow the unit to cool off and all vapors to dissipate before attempting another start.
- **Oil-Flooded Appliance:** Shut off the electrical power and the oil supply to the burner and then clear all accumulated oil before continuing.
- If the condition still appears unsafe, contact the Fire Department. Carefully follow their directions.
- Keep a fire extinguisher nearby and ready for use.

- d. Slide the nozzle line assembly forward until the retention head engages the fixed stops in the retention ring at the end of the air tube. Refer to Figure 10.
- e. Tighten the zero setting locking nut.
- f. The rear door must be closed. The adjustment screw may now be turned clockwise to adjust the head/air setting.
- g. Turn the adjusting screw to a setting 1/2 number lower than the proper setpoint as indicated in Table 1. Then turn the adjusting screw counterclockwise to the proper setting.
- h. Tighten the locking nut after the head/air setting has been adjusted.

Set Combustion with Test Instruments

CAUTION Oil-Burning Equipment shall be connected to flues having sufficient draft at all times to assure safe and proper operation of the burner.

1. Allow the burner to run for approximately 5 to 10 minutes.

NOTICE

The NX burner has a reduced diameter air tube, precision-designed air throttle cup and combustion head for improved performance. This design provides very accurate control of the air/fuel ratio, but the light reaching the cad cell through small holes in these components is limited. Because of this, **the average cad cell resistance may be higher than conventional burners** with larger openings.

2. Set the stack or over-fire draft to the level specified by the appliance manufacturer.
 - o **Natural Draft Applications;** typically over-fire draft is -0.01" or -0.02" w.c.
 - o **Direct Venting;** typically may not require draft adjustment.
 - o **High Efficiency/Positive Pressure Appliances;** also vary from traditional appliances (see manufacturer's recommendations).
3. Follow these five steps to properly adjust the burner:

Step 1: Adjust the head/air until a trace of smoke is achieved. This can be accomplished by turning the screw on the head/air adjustment plate assembly to increase air (CCW) or decrease air (CW).

Step 2: At the trace of smoke level, measure the CO₂ (or O₂). This is the vital reference point for further adjustments. Example: 13.5% CO₂ (2.6% O₂)

Step 3: Increase the air to reduce the CO₂ by 1.5 to 2 percentage points. (O₂ will be increased by approximately 2.0 to 2.7 percentage points.) Example: Reduce CO₂ from 13.5% to 11.5% (2.6% to 5.3% O₂).

Step 4: Recheck smoke level. It should be Zero.

This procedure provides a margin of reserve air to accommodate variable conditions.

If the draft level has changed, recheck the smoke and CO₂ levels and readjust burner, if necessary.

Step 5: Once the combustion has been set, tighten the lower acorn nut and splined nut on the air adjustment assembly. See Figure 9.

4. Chimney Vent Systems: Install the burner cover and repeat Steps 2 and 4 above. If CO₂ increases (O₂ decreases), remove the cover and adjust the air setting so the CO₂ (O₂) with the cover installed meets the requirements of Step 3.
5. Direct Vent Systems with outside air ducted to burner: Install the burner cover.
6. Start and stop the burner several times to ensure satisfactory operation. Test the primary control and all other appliance safety controls to verify that they function according to the manufacturer's specifications.

Figure 10. – Nozzle Line/Head/Air Tube Assembly (Low firing rate shown.)

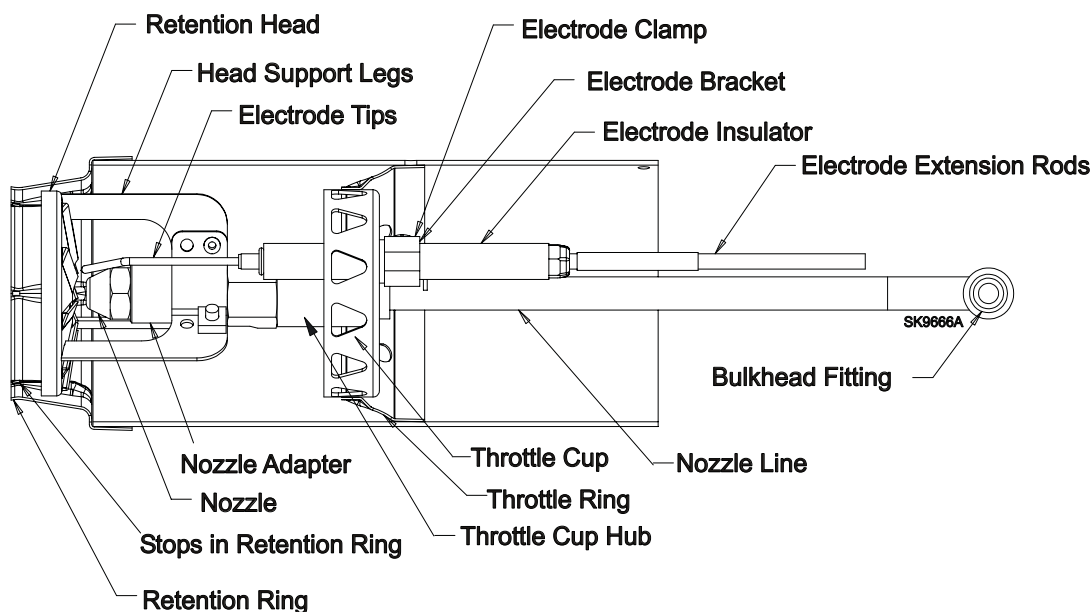

Cover Installation

1. Install the four cover mounting thumb screws in the cover mounting plate.
2. Install the cover over the mounting plate while aligning the side slots with the installed cover mounting screws.

Figure 11. – Burner Cover

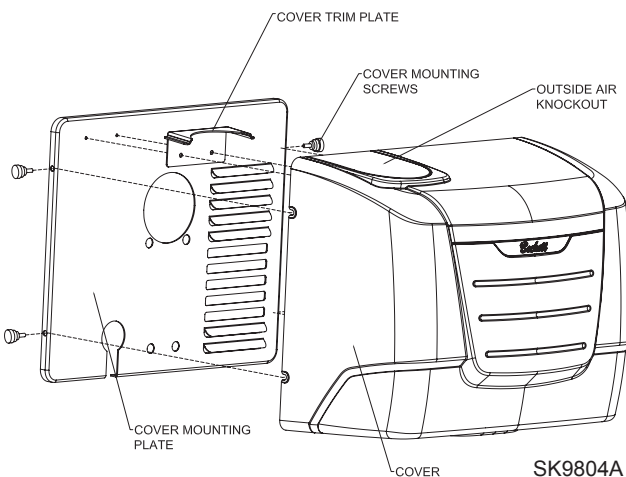

The following guidelines are provided for routine maintenance.

- Replace the oil supply line filter. The line filter cartridge must be replaced to avoid contamination of the fuel pump and nozzle.
- Inspect the oil supply system. All fittings should be tight and leak-free. The supply lines should be free of water, sludge and other restrictions.
- Remove and clean the pump strainer if applicable.
- Replace the used nozzle with a new nozzle that conforms to the appliance manufacturer's specifications.
- Clean and inspect the electrodes for damage, replacing any that are cracked or chipped.
- Check electrode tip settings. Replace electrodes if tips are rounded.
- Inspect the igniter spring contacts.
- Clean the cad cell lens surface, if necessary.
- Make sure Low Firing Rate Baffle is in place if required for the burner application. Omitting the baffle can result in unacceptable burner combustion.
- Inspect all gaskets. Replace any that are damaged or would fail to seal adequately.
- Clean the blower wheel, air inlet, air guide, retention head, throttle cup and throttle ring of any lint or foreign material.
- **Use a clean soft cloth with a degreaser to clean any accumulated soot or oil stains from the throttle cup sight windows.**

Trained Service Technician's Regular Maintenance

WARNING Annual Professional Service Required



Tampering with or making incorrect adjustments could lead to equipment malfunction and result in asphyxiation, explosion or fire.

- DO NOT TAMPER WITH THE UNIT OR CONTROLS - CALL YOUR QUALIFIED SERVICE TECHNICIAN OR SERVICEMAN.
- To ensure continued reliable operation, a qualified service technician must service this burner annually.
- More frequent service intervals may be required in dusty or adverse environments.
- Operation and adjustment of the burner requires technical training and skillful use of combustion test instruments and other test equipment.

WARNING

Do Not Puncture, Scratch, or Remove Flame Sighting Windows



If a window is punctured, significantly scratched or removed from the throttle cup, the burner performance could be impaired, resulting in safety lockout, appliance soot-up, equipment damage, hot gas puff-back and asphyxiation hazard.

- Use a clean soft cloth and degreaser, on an annual basis, to remove any build-up or dark stains from the windows.
 - If damaged, replace the nozzle line assembly with an assembly that has a windowed throttle cup.
-
- Check motor current. The amp draw should not exceed the nameplate rating.
 - Check all wiring for secure connections or insulation breaks.

- Check the pump pressure and cutoff function.
- Check primary control safety lockout timing.
- Check ignition system for proper operation.
- Inspect and clear the vent system and chimney of any soot accumulation or other restriction.
- Clean all flue passages and flue pipe. Replace corroded or damaged pipes.
- Clean the appliance thoroughly according to the manufacturer's recommendations.
- Check the burner performance. Refer to the section "Set combustion with test instruments".
- It is good practice to keep a record of the service performed and the combustion test results.

Removing Nozzle Line for Service

(Reference the Replacement Parts Diagram.)

WARNING Electrical Shock Hazard



Electrical shock can cause severe personal injury or death.

Disconnect electrical power before installing or servicing the burner.

Provide ground wiring to the burner, metal control enclosures and accessories. (This may also be required to aid proper control system operation.)

Perform all wiring in compliance with the National Electrical Code ANSI/NFPA 70 (Canada CSA C22.1)

1. Before proceeding, turn off the main power switch to the burner.
2. Remove the burner cover by loosening the four thumb screws (two on each side of burner).
3. Disconnect the copper connector tube assembly from the nozzle line bulkhead fitting.
4. Loosen the two screws securing the igniter retaining clips and rotate both clips to release the igniter baseplate. The igniter should pop up and be supported by the prop spring.

WARNING

Correct Nozzle and Flow Rate Required



Incorrect nozzles and flow rates could result in impaired combustion, under-firing, over-firing, sooting, puff-back of hot gases, smoke and potential fire or asphyxiation hazards.

Use only nozzles having the brand, flow rate (gph), spray angle and pattern specified by the appliance manufacturer or Beckett Residential Burner OEM Spec Guide, Part #6711.

Follow the appliance manufacturer's specifications for the required pump outlet pressure for the nozzle, since this affects the flow rate.

- Nozzle manufacturers calibrate nozzle flow rates at 100 psig.
- This burner utilizes pressures higher than 100 psig, so the actual nozzle flow rate will be greater than the gph stamped on the nozzle body. (Example: A 1.00 gph nozzle @ 140 psig = 1.18 gph)

For typical nozzle flow rates at various pressures see accompanying chart.

-
5. Loosen the two screws securing the rear door. Swing the door to the right and down.
 6. Loosen the splined nut.
 7. Remove the nozzle line electrode and head assembly from the burner by drawing it straight back and out the rear door opening. The adjustment mechanism is still attached. Be careful not to damage the electrodes or insulators while handling.
 8. To replace the nozzle assembly, reverse the above procedure.

Nozzle Installation

CAUTION

Protect Nozzle from Damage

A damaged nozzle could cause impaired combustion, sooting, puffback of hot gases, smoke, oil leakage and potential fire or asphyxiation hazards.

- Use care when handling, removing and installing oil nozzles.
 - Carefully follow the guidelines provided in this section.
-

Perform the following steps when replacing a nozzle.

1. Remove the nozzle line assembly to gain access to the nozzle.
2. Use a 3/4" open-end wrench to hold the nozzle adapter. DO NOT attempt to remove or replace the nozzle without securing the adapter, as nozzle alignment could be seriously affected.
3. Do not squeeze the electrodes when handling the nozzle line assembly. Excessive force could change the electrode tip settings or damage the ceramic electrode insulators.
4. Use a 5/8" open-end wrench to carefully remove the existing nozzle.
5. Inspect the nozzle adapter before installing the new nozzle. If it is grooved or scratched on the sealing surface, replace the nozzle line assembly. If the surface is damaged, oil could leak at the nozzle to adapter joint, causing serious combustion problems.
6. Protect the nozzle orifice and strainer when installing. If the orifice gets dirt in it or is scratched, the nozzle will not function properly.
7. To install a new nozzle, place a 3/4" open-end wrench on the nozzle adapter. Insert the nozzle into the adapter and secure finger tight. Finish tightening with a 5/8" open-end wrench. Use care to avoid bending the burner head support legs or electrodes.
8. Do not over-torque the nozzle when installing. This will cause deep grooves in the nozzle adapter, preventing a seal when a new nozzle is installed.
9. Carefully check and realign the electrode tips after replacing a nozzle, ensuring the electrode settings comply with Figure 12.
10. If the head was removed when replacing the nozzle, carefully reconnect the head to the nozzle adapter. Make sure to align the key in the support leg with the keyway in the nozzle adapter and to butt the head support to the nozzle adapter shoulder, see Figure 10.

Table 6 - Nozzle Flow Rate by Size

Nozzle flow rate U. S. gallons per hour of No. 2 fuel oil when pump pressure (psig) is:					
Nozzle size (rated at 100 psig)	125 psi	140 psi (factory std.)	150 psi	175 psi	200 psi
0.40	0.45	0.47	0.49	0.53	0.56
0.50	0.56	0.59	0.61	0.66	0.71
0.60	0.67	0.71	0.74	0.79	0.85
0.65	0.73	0.77	0.80	0.86	0.92
0.75	0.84	0.89	0.92	0.99	1.06
0.85	0.95	1.01	1.04	1.13	1.20
0.90	1.01	1.07	1.10	1.19	1.27
1.00	1.12	1.18	1.23	1.32	1.41
1.10	1.23	1.30	1.35	1.46	1.56
1.20	1.34	1.42	1.47	1.59	1.70
1.25	1.39	1.48	1.53	1.65	1.77
1.35	1.51	1.60	1.65	1.79	-
1.50	1.68	1.77	1.84	-	-
1.65	1.84	-	-	-	-
1.75	-	-	-	-	-

Check/Adjust Electrodes

Check the electrode tip settings, as shown in Figure 12. If necessary, adjust by loosening the electrode clamp screw (Figure 10) and slide/rotate the electrodes as necessary. When the adjustment is complete, securely tighten the clamp screw.

Note that if the throttle cup is moved be sure to reposition it with no gap between the nozzle adapter and hub.

Figure 12. – Electrode tip gap and spacing

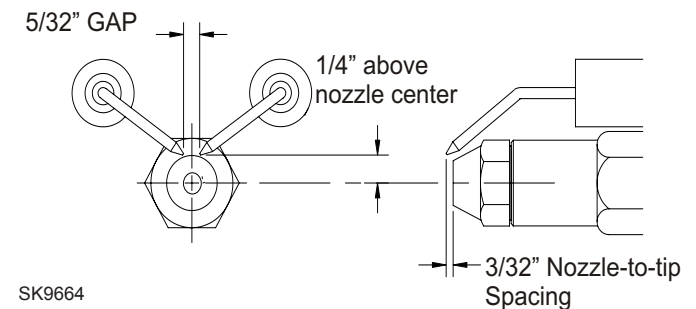

Check Retention Head Alignment and Cad Cell Sighting

(Refer to Figure 13.)

The cad cell sighting holes in the throttle cup and the retention head must be aligned to allow the cad cell to detect the flame. Make sure the stamped key in the retention head collar lines up with the keyway in the nozzle adapter when mounting the retention head. Note that in specific applications, the retention head may not have a sighting hole.

Check/Adjust "Zero" Calibration

On burners with factory-installed air tubes, the zero calibration has been factory set. Make sure the retention head (Figure 10) is securely against the stops in the retention ring when the adjustment plate pointer is at "0" (Figure 9).

If the zero calibration has not been set, perform the following procedure:

1. Install the nozzle line, with the adjustment plate assembly attached, into the burner.
2. Install and tighten the rear door to hold the air adjustment plate assembly in position.
3. Slightly loosen the upper acorn nut, the splined nut, and the lower acorn nut.

4. Turn the air adjustment screw clockwise to adjust the plate with the pointer to the zero position.
5. Referring to Figure 10, slide the nozzle line assembly forward until the retention head engages the fixed stops in the retention ring at the end of the air tube.
6. Tighten the upper acorn nut securely.
7. The rear door must be kept tightly closed. The adjustment screw may now be turned to adjust the head/air setting.
8. Turn the adjusting screw to a setting $\frac{1}{2}$ number lower than the proper set point as indicated in Table 1. Then turn the adjusting screw counterclockwise to the proper setting.
9. Tighten the splined nut and lower acorn nut after the head/air setting has been adjusted.

Blower Wheel Replacement

For installation or replacement of a blower wheel, insure that there is a space between the blower wheel and the motor face of 0.115". Refer to Figure 14.

Shutting the Burner Off

Turn off all electric power to the burner.

Note: There could be more than one disconnect switch.

 **CAUTION** If the burner is shut down for an extended period of time, always keep the valve shut off.

Figure 13. – Retention Head/Throttle Cup Alignment

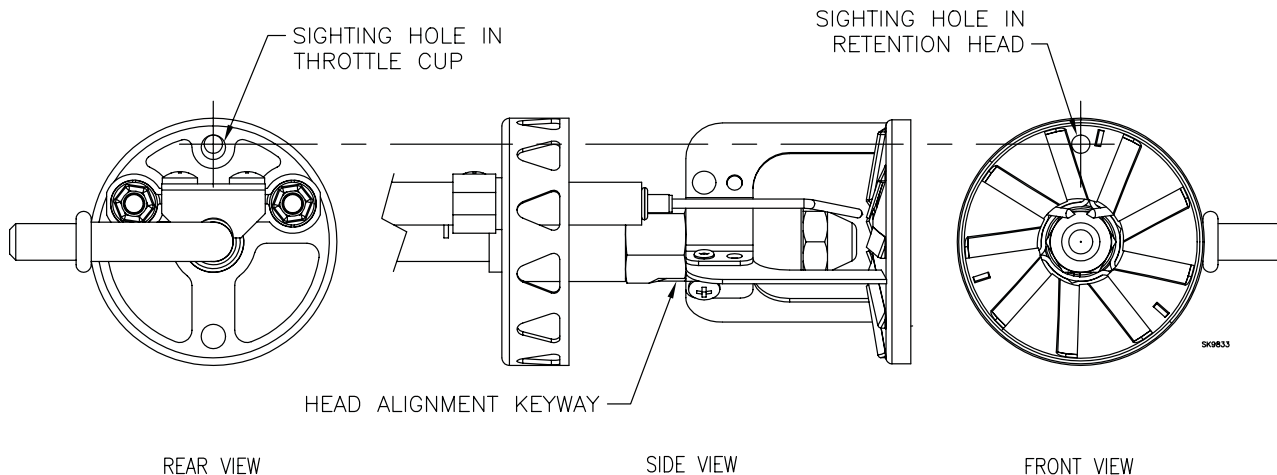
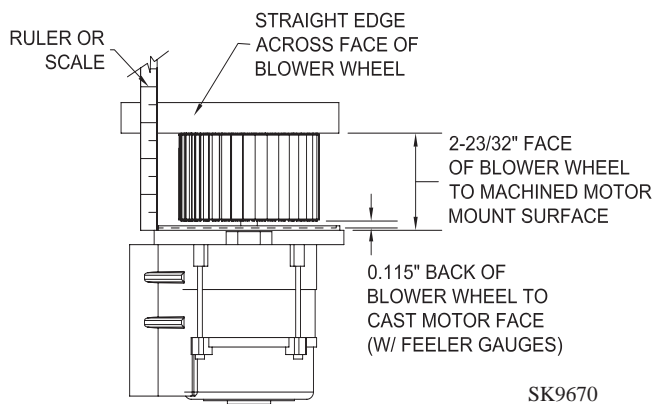
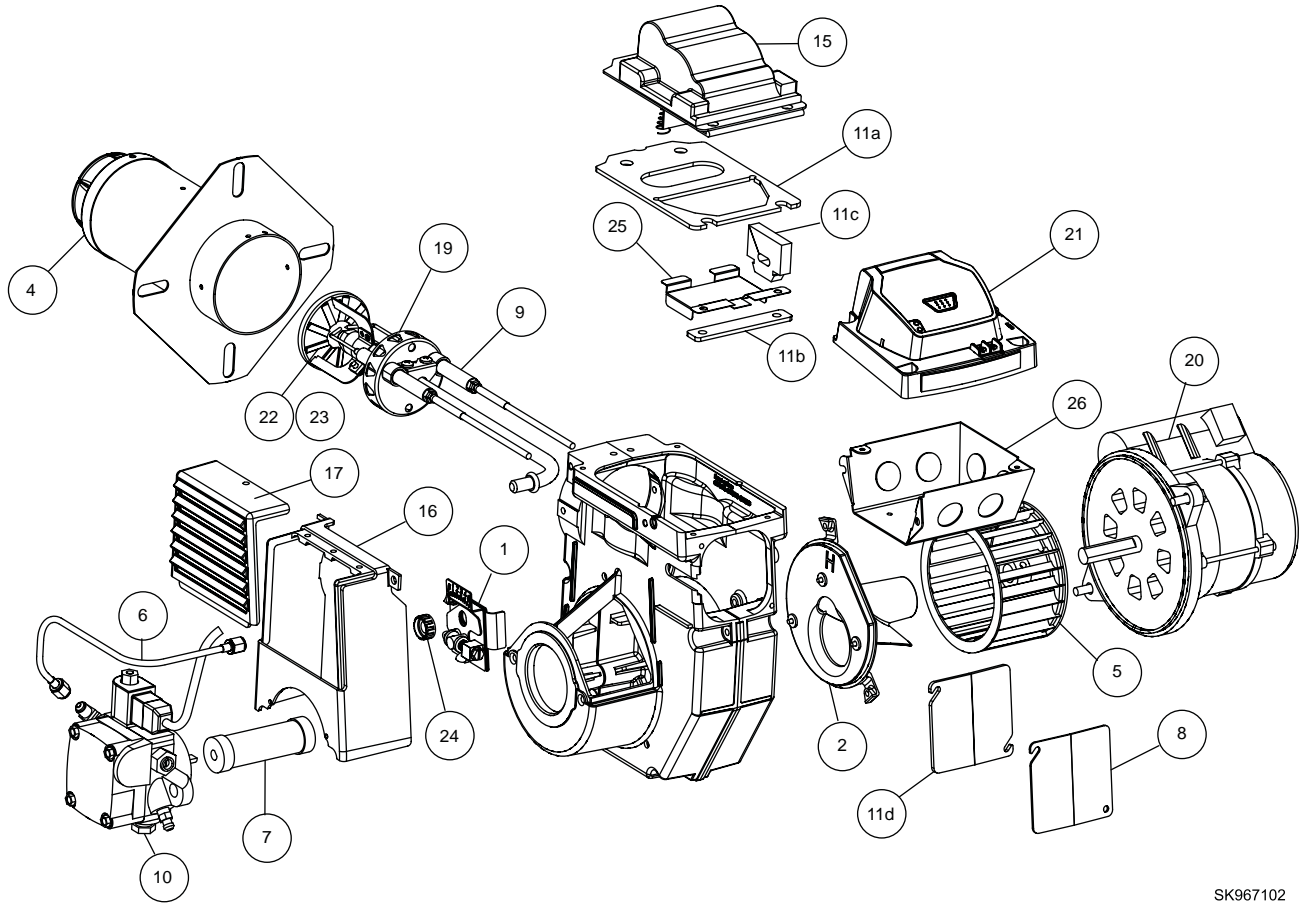

Figure 14. – Blower wheel assembly



Replacement Parts

For best performance specify genuine *Beckett* replacement parts



SK967102

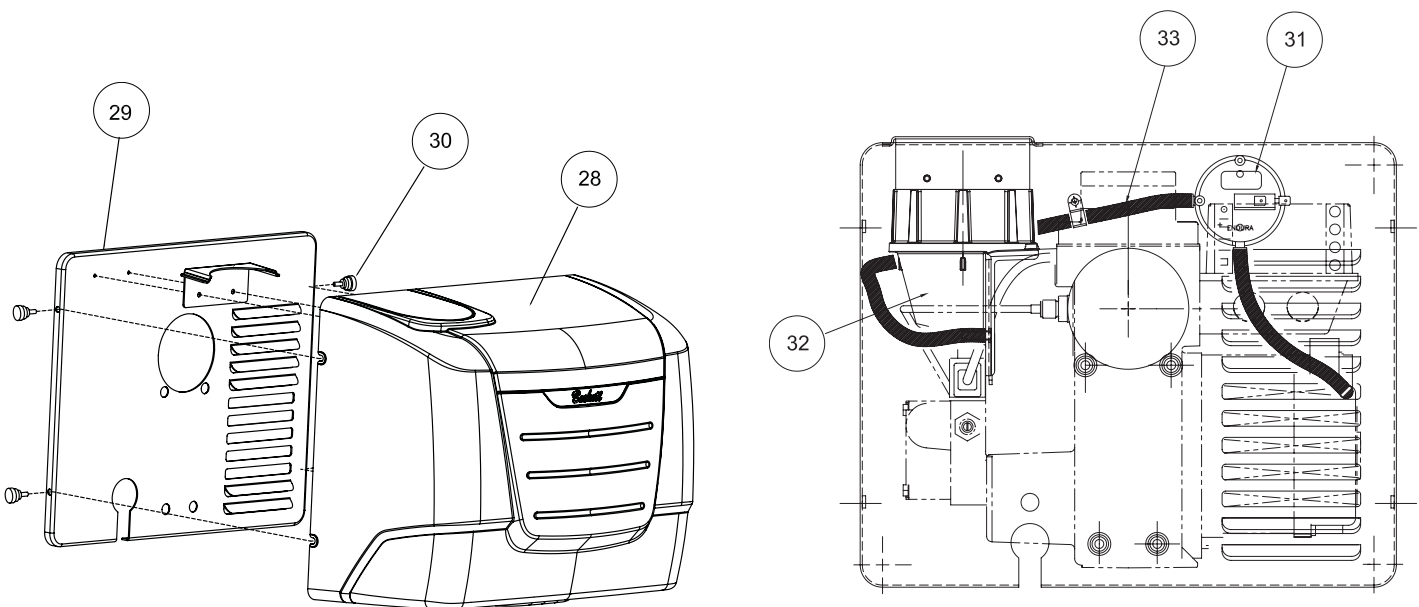

Item	Description	Part No.
1	Head/Air adjustment mechanism assembly	52000U
2	Air guide	101101U
3	Gasket, mounting flange (not shown)	32389
4	Air tube combination, (Includes Screws, air tube mounting #8 x 3/8)	Specify 4396
5	Blower wheel	2999U
6	Connector tube assembly, 11"	51127
7	Coupling	2454
8	Door, rear access	32119U
9	Electrode insulator kit	51811U
10	CleanCut Fuel Pump, (Requires Mounting Screws ¼ -20 x 7/8")	2184404U 4189
11a	Gasket, igniter baseplate	51942U
11b	Gasket, igniter baseplate hinge	51942U
11c	Gasket, wiring	51942U
11d	Gasket, rear access door	51942U
15	Igniter, electronic	51771U
16	Inlet air box	1010U
17	Inlet air louvers	1013U
19	Nozzle Line Electrode and Head Assembly	Specify

20	PSC Motor, (Requires Mounting screws ¼ -20 x 7/8")	21805U 4189
21	Primary control	7505P
22	Retention head assembly, 6 -slot	51785U
23	Retention head assembly, 9 -slot	51815U
24	Splined nut	3666
25	Spring, igniter prop	32058U
26	Electrical box	5770
28	Cover, burner	32395U
29	Mounting plate, burner cover	32399U
30	Thumbscrews, cover mounting	21899U
31*	Pressure Switch Kit, including switch, (2) hoses & pressure switch/cad cell lead	21985U
32*	Outside air adapter w/Pressure Port	52018U
33*	Parts kit, Including (2) hoses & pressure switch/cad cell lead	51988U
	NX Outside Air Kit; includes outside air adapter, vacuum relief valve & intake air hood	51990U
	Combustion Blanket (Requiredf for 3, 4, and 5 section Direct Vent Boilers.)	31489

* Denotes an optional part per burner specification.

Limited Warranty Information

The R. W. BECKETT CORPORATION ("Beckett") warrants to persons who purchase its "Products" from Beckett for resale, or for incorporation into a product for resale ("Customers"), that its equipment is free from defects in material and workmanship. To qualify for warranty benefits, products must be installed by a qualified service agency in full compliance with all codes and authorities having jurisdiction, and used within the tolerances of Beckett's defined product specifications.

To review the complete warranty policy and duration of coverage for a specific product, or obtain a written copy of warranty form 61545, please choose one of the following options:

1. Visit our website at: www.beckettcorp.com/warranty
2. Email your request to: rwb-customer-service@beckettcorp.com
3. Write to: R. W. Beckett Corporation, P. O. Box 1289, Elyria, OH 44036

NOTE: Beckett is not responsible for any labor cost for removal and replacement of equipment.

THIS WARRANTY IS LIMITED TO THE PRECISE TERMS SET FORTH ABOVE, AND PROVIDES EXCLUSIVE REMEDIES EXPRESSLY IN LIEU OF ALL OTHER REMEDIES, AND IN PARTICULAR THERE SHALL BE EXCLUDED THE IMPLIED WARRANTIES OF MERCHANTABILITY AND FITNESS FOR A PARTICULAR PURPOSE. IN NO EVENT WILL BECKETT BE LIABLE FOR ANY INCIDENTAL OR CONSEQUENTIAL DAMAGE OF ANY NATURE. Beckett neither assumes, nor authorizes any person to assume for Beckett, any other liability or obligation in connection with the sale of this equipment. Beckett's liability and Customer's exclusive remedy is limited to the cost of the product.

