

*Beckett*

PARTS & ACCESSORIES

# GeniSys™ 12V

## Model 7556

Advanced 12 Vdc Burner Control



## Description / Applications

The Beckett GeniSys™ 12V Advanced Burner Control is a 12 Vdc primary safety control for oil burners used in special applications including, but not limited to, water heaters, pressure washers, crack sealers and portable heaters having firing rates less than 5.5 GPH. The GeniSys™ 12V is used with a suitable cad cell flame sensor to control the oil burner motor, igniter, and optional solenoid valve. It has 12 volt enable input compatible with mechanical and high limit switches. It can provide interrupted or intermittent duty ignition, and it has a 15 second lockout time on flame failure.

GeniSys™

# Features

- Welded Relay Protection
- Limited Relight
- Valve-On Delay / Motor-Off Delay (Field programmable with Beckett's Contractor Tool)
- 15 Second Lockout Time
- Interrupted Ignition
- Communication Port
- Lockout Alarm Output

# Specifications

**CAUTION** Do Not Use This Control in an Application that is Not Within the Ratings Listed in This Section. Improper Control Operation May Result.

**CAUTION** Do Not Use This Control Above 5.5 GPH

## Electrical Ratings

### Inputs:

- Voltage: 12 Vdc nominal (11 to 16 Vdc)
- Current: 160 mA nominal (500 mA max at 16 Vdc)\*
- Enable Load: 40mA at 12 Vdc

### Outputs:

- Motor: 12 Vdc, 20 full load amps (FLA), 100 locked rotor amps (LRA)
- Igniter: 12 Vdc, 5 A
- Solenoid Valve: 12 Vdc, 2 A
- Lockout Alarm: 12 Vdc, 2A

\* **NOTICE** The 7556 control draws 60-75mA in the standby state. If the red control wire is left powered without a battery charging system, it can drain a standard 45 Amp hour automotive battery in two to four weeks.

## Environmental Ratings:

- Storage and Operating Ambient Temperature: -40°F to +160°F (-40°C to +71°C)
- Moisture: 5 to 95% RH, condensing

**WARNING** Maintain Specified Voltage

*A low or erratic power supply could result in impaired burner operation, severe delayed ignition or an explosion inside the heat exchanger resulting in a burn and/or asphyxiation hazard.*

- Beckett DC Burners require a continuous supply of 11 to 16 volts DC (at 15 amps for Model ADC or 25 amps for Model SDC), measured at the burner during operation.
- Consult other DC burner manufacturers' specifications for the correct voltage range.
- **Special Note: The 7556 Control shuts the burner down if the input voltage drops to a sustained level of 10 volts DC, or below. Operation resumes at a sustained input voltage of 11 volts DC, or above.**
- An automotive or small engine charging system that is capable of supplying the required continuous voltage/ampage is recommended with certain road equipment, such as asphalt hot patchers and similar applications.
- This is especially true while maintaining nominal load temperatures during idle periods.

**Table 1 - Model Guide**

| Beckett GeniSys 12V Control Part No. | Lockout Time | Valve-on delay time <sup>1</sup> | Motor-off delay time <sup>1</sup> |
|--------------------------------------|--------------|----------------------------------|-----------------------------------|
| 7556A 0000 <sup>1</sup>              | 15 sec       | 0 sec                            | 0 sec                             |
| 7556P 1530 <sup>1</sup>              | 15 sec       | 15 sec                           | 30 sec                            |
| 7556P 151M <sup>1</sup>              | 15 sec       | 15 sec                           | 1 min                             |
| 7556P 152M <sup>1</sup>              | 15 sec       | 15 sec                           | 2 min                             |
| 7556P 158M <sup>1</sup>              | 15 sec       | 15 sec                           | 8 min                             |

1 - Valve-on delay and motor-off delay timings on all models are programmable with the Beckett Contractor Tool. Other factory set timings are available. Contact Beckett for alternate timings.

# Installation/Operation/Maintenance



## WARNING

### Professional Service Required.

*Incorrect installation or misuse of this control could result in severe personal injury or death from heavy smoke, explosion or fire.*

Please read and understand the manual supplied with this control. This control must be installed, adjusted and put into operation only by a qualified individual or service agency that is:

- Licensed or certified to install and provide technical service to oil heating systems.
- Experienced with all applicable codes, standards and ordinances.
- Responsible for the correct installation and commission of this equipment.
- Skilled in the adjustment of oil burners using combustion test instruments.

The installation must strictly comply with all applicable codes, authorities having jurisdiction and the latest revision of the National Fire Protection Association Standard for the Installation of Oil-Burning Equipment, NFPA 31 (or CSA-B139 and CSA-B140 in Canada) for stationary equipment. Regulation by these authorities take precedence over the general instructions provided in this installation manual.



## WARNING

### Electrical Shock Hazard

*Electrical shock can cause severe personal injury or death.*

- Disconnect ALL electrical power to the equipment/burner circuit before installing or servicing this control.
- Provide ground wiring to the equipment, burner and metal control mounting box.
- Perform all wiring in compliance with the National Electrical Code ANSI/NFPA 70 (Canada CSA C22.1).



## WARNING

### Explosion, Fire, Scald, & Burn Hazard



*All heating equipment must have HIGH LIMIT controls to protect against excessive temperature and/or pressure. The control must interrupt electrical power and shutdown the burner, if operating or safety controls fail and cause a runaway condition.*

- Follow the equipment manufacturer's wiring diagrams and note all required safety controls.
- Typical safety controls include high temperature or pressure limits, low water cutoffs, pressure relief valves and blocked flue sensing switches.
- Verify all limit and safety controls are installed and functioning correctly, as specified by the manufacturer, applicable safety standards, codes and all authorities having jurisdiction.
- Insure that the equipment is free of oil and oil vapor before starting or resetting the burner.

**Do not wire power directly to the burner motor. Only wire the motor as shown in Figure 2. If instant burner heat is required by the application, purchase or program a control with a long motor-off delay time, which will ensure instant heat if a new call for heat is received within the motor-off delay time.**

### Mounting:

Mount the control on a 4" x 4" junction box on the burner, or inside the equipment cabinet. In replacement applications, mount the new control in the same location as the old control. In some replacement applications, it may be necessary to rotate the control on the 4" x 4" box for best fit. Mounting orientation: any orientation is acceptable with the exception of up-side down.

**Figure 1 – Getting to know the control**

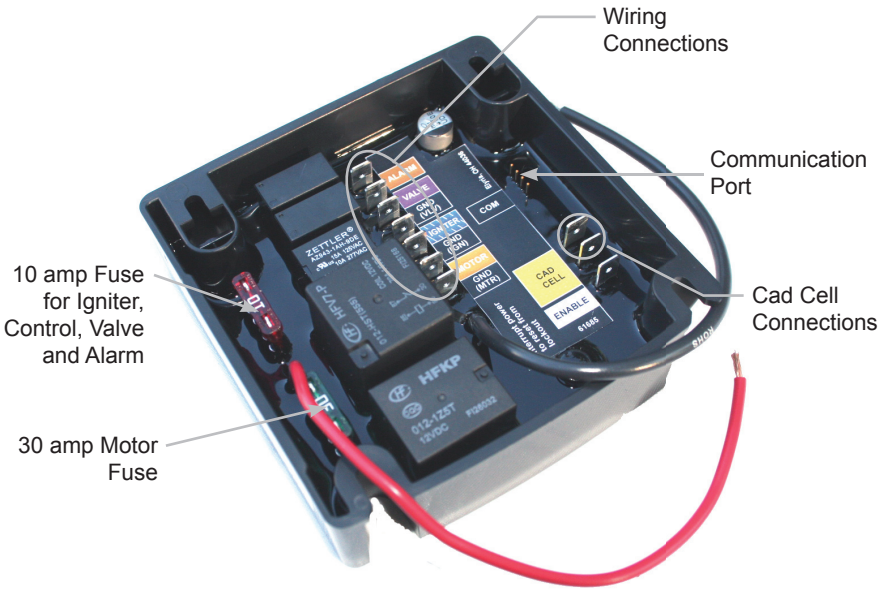

**Figure 2 – Typical Wiring for Interrupted Ignition (With or without Valve-on Delay or Motor-off Delay.)**

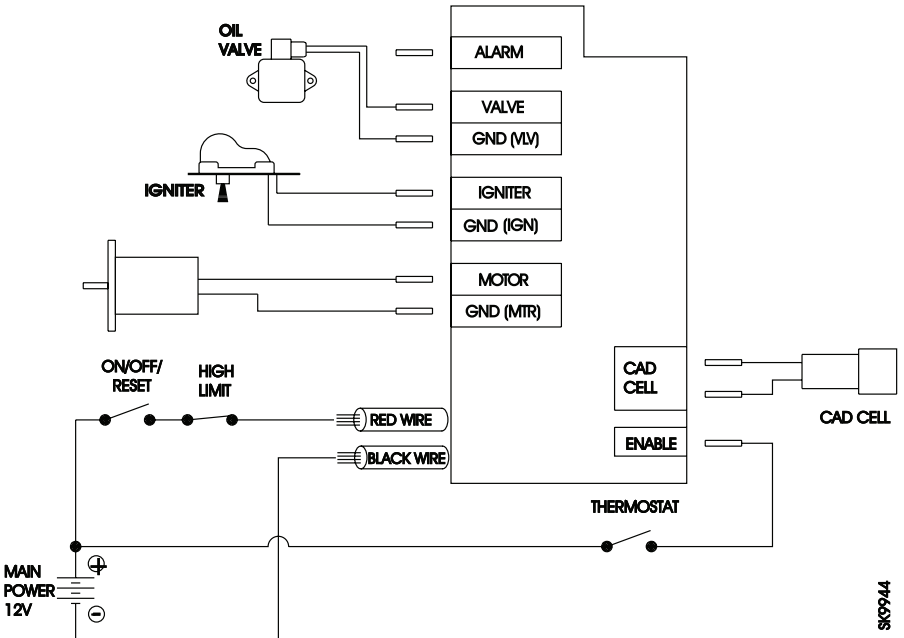

SK0944

## Wiring:



### Incorrect Wiring Will Result in Improper Control Operation

- GeniSys 12V wiring label colors may not match the wire colors of the burner or other manufacturers' controls.
  - The GeniSys 12V Control should be wired according to the equipment manufacturer's instructions.
- 
- Make sure all equipment wiring complies with all local codes and ordinances.
  - Make connections to the control's terminals as shown in **Figure 2**. Refer to the label on the underside of the control for wiring details.
  - Motor-off delay on a 7556P will be disabled if the safety and operating limits as shown in **Figure 2** interrupt power to the control's red +12 volt wire.
  - Input power to the control's red +12 volt wire must be provided from a fused service switch, rated at 50 amps or less.

### Replacing a 7434 Control with a 7556 Control (Refer to Fig. 1 & 2.)

- Remove the 7434.
- Remove unused wires from the 7556.
- Connect the cad cell wires to the 7556 yellow wires.
- Connect the white wire to the thermostat or high limit output. If the white wire from the 7434 was connected into the red with white stripe wire or to the red wire, use a wire nut to connect the white and red input wires from the 7556.
- Connect the red motor wire to the orange wire on the MOTOR terminal and the black motor wire to the black wire on the GND (MOTOR) terminal.
- Connect the red igniter wire to the blue with white stripe wire on the IGNITER terminal and the black igniter wire to the black wire on the GND (IGNITER) terminal.
- Connect the violet valve wire to the violet wire on the VALVE terminal and the white valve wire to the black wire on the GND (VALVE) terminal.
- Connect the 7556 red wire to the same connection as the 7434 red wire. Note that

to utilize the motor-off delay, the red wire must remain powered after the call for heat ends (Enable input turned off).

- Connect the 7556 black input wire to the same connection as the 7434 black input wire with ring terminal.

## Startup / Checkout

If the burner or control fails any of the following tests, recheck control wiring. If the burner or control still fails any tests, replace the control.

### Starting the System

1. Open the shut-off valve(s), if applicable, in the supply line from the oil tank.
2. Close the disconnect switch to supply power to the burner.
3. Adjust the thermostat to call for heat.
4. If the pump has not been primed, refer to "Priming the Pump" in this manual.
5. Monitor burner operation to insure that the burner ignites.
6. End the call for heat. Verify that the burner turns off before leaving the installation site.

## Check Safety Features

### Safe Start Check

1. Place a jumper across the cad cell terminals.
2. Refer to the steps for "Starting the System" and have the system call for heat.
3. Burner must not start. Verify that the control remains in Standby mode.
4. End the call for heat and remove the cad cell jumper.

### Simulate Flame Failure and Ignition Failure

1. Refer to the steps for "Starting the System" and have the system call for heat.
2. After flame is established and the burner igniter turns off (if wired for interrupted ignition), simulate flame failure by pulling

- the cord set out of the solenoid valve.
- At flame loss, the control will enter Relight mode. The control will immediately turn the igniter on.
  - After the 15 second lockout time, the control will lock out the burner. Verify that the burner motor and igniter are off and that the burner oil solenoid valve (if used) is not energized.
  - Push the cord set back in.

- To reset the control from lockout, turn off power to the control for at least 2 seconds.
- Turn power on and verify that the burner lights.
- End the call for heat.

Insure that all control wiring is correct prior to securing the control. Consult equipment manual for details.

## Sequence of Operation



*Reset and Service by Qualified Technician only.*

### Burner States

- Standby:** The burner is idle, waiting for a call for heat.
- Valve-On Delay:** The igniter and motor are on while the control delays turning on the oil solenoid valve for the programmed time.
- Trial For Ignition:** The oil solenoid valve is energized. A flame should be established within the factory set trial for ignition time (“lockout time”).
- Lockout:** The control has shut down for one of the following safety reasons:
  - The trial for ignition (lockout) time expired without flame being established.
  - The cad cell detected flame at the end of the Valve On Delay state.
  - The pre-set time allotment for relighting is exceeded.
  - Failed welded relay check.

If the control detects a welded motor contact, the motor only will cycle 5 seconds on, 5 seconds off, 3 times before locking out.

To reset the control from lockout interrupt power for at least 2 seconds.

- Ignition Carryover:** Once flame is established, the igniter remains on for

10 additional seconds to ensure flame stability.

- Run:** The flame is sustained until the call for heat is satisfied. The control then switches to Motor-Off Delay, if applicable, or it shuts down and returns to Standby.
- Relight:** If the flame is lost while the burner is firing, the control immediately repeats the ignition sequence. The control will continue to Relight each time the flame is lost, until it reaches a pre-set time allotment. The control will then go into Lockout instead of Relight. This feature prevents excessive accumulation of oil in the equipment's combustion chamber.
- Motor-Off Delay:** If applicable, the oil solenoid valve is turned off and the control delays turning the motor off for the set motor-off delay time before the control returns to standby. Note that to utilize the motor off delay, power must remain to the red wire after the call for heat ends. (Enable input turned off, see *Figure 2.*)

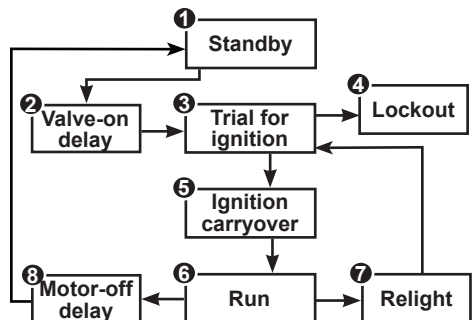

## Priming the Pump



### WARNING

#### Hot Gas Puff-Back & Heavy Smoke Hazard

*Failure to bleed the pump properly could result in unstable combustion, hot gas puff-back and heavy smoke.*

- Do not allow oil to spray into a hot combustion chamber while bleeding air from the pump.
- Install a gauge in the nozzle discharge port tubing or fully open the pump bleed valve to prevent oil spray from accumulating in the combustion chamber during the air bleed procedure.
- Insure that all bubbles and froth are purged from the oil supply system before tightening the pump bleed valve.
- Insure that the equipment is free of oil and oil vapor before starting or resetting the burner.

1. Prepare the burner for priming by attaching a clear plastic hose over the bleed port fitting and fully opening the pump bleed port. Use a suitable container to collect purged oil.
2. Initiate a call for heat.
3. Bleed the pump until all froth and bubbles are purged. If desired, terminate the call for heat to return to Standby.
4. If prime is not established during the valve on delay and the trial for ignition times, repeat Step 3 until the pump is fully primed and the oil is free of bubbles.
5. Terminate the call for heat, and the control will resume normal operation.

## Resetting From Lockout



### WARNING

#### Fire & Smoke Hazard



*Before starting or resetting the control from lockout state, troubleshoot the heating system for the root cause(s) of the lockout.*

1. Make necessary repairs or adjustment to ensure a safe start condition.
2. Insure that the equipment is free of oil and oil vapors before starting or resetting the burner.

1. To reset, interrupt power for at least 2 seconds.
2. Always verify the control functions according to all specifications before leaving the installation site.
3. Replace the control if it does not operate as specified.

## Maintenance

Oil heating systems require annual service performed by a qualified, professional service agency. The 7556 primary control should be inspected during this service routine according to the following checklist:

### NOTICE

The 7556 control has no serviceable internal parts.

- Inspect the exterior of the control. Replace the control if there is any sign of impact damage.
- Use a multimeter to test the input voltage at the control. It should read 11 to 16 Vdc.
- Inspect all external wiring for secure connections and verify insulation integrity.
- Verify the control lockout and operation sequence, (Reference *Startup/Checkout* section).
- Observe a full operating cycle to prove the sequence and timings are correct.
- Replace any control that does not meet listed specifications. Always replace with the parts specified by the equipment manufacturer.
- Replace a blown fuse with an equivalent fast-acting automotive blade style fuse (refer to **Figure 1** for fuse ratings and locations).

# Limited Warranty Information

The R. W. BECKETT CORPORATION (“Beckett”) warrants to persons who purchase its “Products” from Beckett for resale, or for incorporation into a product for resale (“Customers”), that its equipment is free from defects in material and workmanship. To qualify for warranty benefits, products must be installed by a qualified service agency in full compliance with all codes and authorities having jurisdiction, and used within the tolerances of Beckett’s defined product specifications.

To review the complete warranty policy and duration of coverage for a specific product, or obtain a written copy of warranty form 61545, please choose one of the following options:

1. Visit our website at: [www.beckettcorp.com/warranty](http://www.beckettcorp.com/warranty)
2. Email your request to: [rwb-customer-service@beckettcorp.com](mailto:rwb-customer-service@beckettcorp.com)
3. Write to: R. W. Beckett Corporation, P. O. Box 1289, Elyria, OH 44036

**NOTE: Beckett is not responsible for any labor cost for removal and replacement of equipment.**

THIS WARRANTY IS LIMITED TO THE PRECISE TERMS SET FORTH ABOVE, AND PROVIDES EXCLUSIVE REMEDIES EXPRESSLY IN LIEU OF ALL OTHER REMEDIES, AND IN PARTICULAR THERE SHALL BE EXCLUDED THE IMPLIED WARRANTIES OF MERCHANTABILITY AND FITNESS FOR A PARTICULAR PURPOSE. IN NO EVENT WILL BECKETT BE LIABLE FOR ANY INCIDENTAL OR CONSEQUENTIAL DAMAGE OF ANY NATURE. Beckett neither assumes, nor authorizes any person to assume for Beckett, any other liability or obligation in connection with the sale of this equipment. Beckett’s liability and Customer’s exclusive remedy is limited to the cost of the product.



**USA:** P.O. Box 1289 • Elyria, OH 44036  
**Canada:** R.W. Beckett Canada, Ltd. • Unit #3, 430 Laird Road • Guelph, Ontario N1G 3X7  
[www.beckettcorp.com](http://www.beckettcorp.com)