

ADC

24Vdc Oil Burner Manual

Beckett™

CORPORATION



WARNING

Potential for Fire, Smoke and Asphyxiation Hazards



Incorrect installation, adjustment, or misuse of this burner could result in death, severe personal injury, or substantial property damage.

To the Homeowner or Equipment Owner:

- Please read and carefully follow all instructions provided in this manual regarding your responsibilities in caring for your heating equipment.
- Contact a professional, qualified service agency for installation, start-up or service work.
- **READ THESE INSTRUCTIONS AND SAVE FOR REFERENCE.**

To the Professional, Qualified Installer or Service Agency:

- Please read and carefully follow all manual instructions and any supplements provided, before installing, starting, or servicing this burner or heating system.
- The Installation must be made in accordance with all state and local codes having jurisdiction.

Contents

- Burner Application Scope and Intended Use 2**
- Prepare Before Installing 3**
 - Notice Special Requirements..... 3
 - Specifications..... 3
- General Information 4**
 - A. Equipment Located in Confined Space 4
 - B. Exhaust Fans and Other Air-Using Devices..... 4
 - C. Clearances to Burner and Equipment 4
 - D. Exhausting Hazardous Fumes 5
 - E. Low Firing Rate Baffle. 5
- Nozzle Assembly Maintenance 5**
 - A. Replace the Burner Nozzle..... 5
 - B. Check/Adjust Electrodes 5
 - C. Igniter Maintenance..... 5
 - D. Servicing Nozzle Line Assembly 6
 - E. Check/Adjust “Z” Dimension..... 6
- Fuel Supply 7**
 - A. Connect Fuel Lines..... 7
 - B. Fuel Supply Level with or Above Burner..... 7
 - C. Fuel Supply Below Level of Burner 7
 - D. Fuel Line Replacement (Remote Tank Only) 7
 - E. Fuel Line Valve and Filter 7
- Burner Wiring..... 8**
 - A. Burner installed on equipment..... 8
 - B. Burner Replacement..... 8
- Drive Component Maintenance..... 9**
 - A. Motor, Blower Wheel, and Coupling Replacement..... 9
 - B. Pump Maintenance..... 9
 - C. Valve Coil and Stem Replacement..... 10
- Start Up Burner & Set Combustion..... 11**
 - A. Basic Burner Operation 11
 - B. Combustion Set-up..... 11
 - C. Set Combustion with Instruments..... 11
- Maintain & Service Burner..... 12**
 - A. Owner’s Information 12
 - B. Owner Service and Maintenance 12
 - Extended Down Time..... 12
 - Regular Service/Maintenance..... 12
- Troubleshooting 13**
- Replacement Parts 15**
- Limited Warranty Information 16**

Hazard Definitions:

 DANGER	Indicates a hazardous situation that, if not avoided, <i>will</i> result in death or serious injury .
 WARNING	Indicates a hazardous situation that, if not avoided, <i>could</i> result in death or serious injury .
 CAUTION	Indicates a hazardous situation that, if not avoided, <i>could</i> result in minor or moderate injury .
 NOTICE	Used to address practices not related to physical injury.
 SAFETY INSTRUCTIONS	Safety instructions signs indicate specific safety-related instructions or procedures.

Burner Application Scope and Intended Use

The DC burner is designed for use in pressure washer, road maintenance equipment, and many other applications that have DC voltage charging systems capable of sustaining the specified voltage requirements. For other equipment applications, please contact Beckett Technical Services at 1-800-645-2876.

Prepare Before Installing

WARNING Owner's Responsibility



Incorrect installation, adjustment, and use of this burner could result in severe personal injury, death, or substantial property damage from fire, carbon monoxide poisoning, soot or explosion.

Contact a professional, qualified service agency for the installation, adjustment and service of your oil heating system. This work requires technical training, trade experience, licensing or certification in some states and the proper use of special combustion test instruments.

Please carefully read and comply with the following instructions:

- Never store or use gasoline or other flammable liquids or vapors near this burner or appliance.
- Never attempt to burn garbage or refuse in this appliance.
- Never attempt to light the burner/appliance by throwing burning material into the appliance.
- Never attempt to burn any fuel not specified and approved for use in this burner.
- Never restrict the air inlet openings to the burner or the combustion air ventilation openings in the room.

WARNING Impaired Burner Performance & Fire Hazard.

Do NOT operate the burner beyond specifications outlined in the table to the right.

- For applications beyond these limits, consult Beckett Technical Service at 1-800-645-2876.
- NOTE: Some packaged appliances with burners may be agency listed as a unit to operate beyond these limits. Consult the appliance manufacturer's specifications and agency approvals for verification.

Notice Special Requirements

NOTICE

If you discover damage to the burner or controls during unpacking, notify the carrier at once and file the appropriate claim.

NOTICE

When contacting Beckett for service information — Please record the burner serial number (and have available when calling or writing). You will find the serial number on the silver label located on the left rear of the burner. See **Figure 1**.

Specifications

See 'Adequate Voltage Required' warning on page 4

Rated Voltage: 27Vdc (Nominal Charging System Voltage)

Reference Voltage: 24V DC (Battery Discharge Voltage)

Capacity	<p><i>Firing Rate (27V): 0.75 – 3.00 GPH</i> <i>Input: 105,000 - 420,000 Btu/h</i></p> <p><i>Firing Rate (24V)*: 0.75 - 2.50 GPH</i> <i>Input: 105,000 - 350,000 Btu/h</i></p>
Fuels	<p>USA: No. 1 or No. 2 diesel fuel or kerosene; No. 1 or No. 2 heating oil (ASTM D396)</p> <p> CAUTION DO NOT USE GASOLINE, CRANKCASE OIL, OR ANY OIL CONTAINING GASOLINE.</p>
Electrical	<p><i>Burner Voltage (nominal): 27 Vdc</i> <i>Voltage Range: 21.6V - 28V</i></p> <p><i>Operating Load</i> <i>w/ igniter on: 9 Amps</i> <i>w/ igniter off: 6 - 8 Amps</i></p> <p><i>Motor Voltage (nominal): 27Vdc</i> <i>Voltage Range: 21.6V - 30V</i> <i>Full Load Amps: 6.1 Amps</i> <i>Starting Amps: 50 Amps</i> <i>1/7 HP, 3500 RPM, NEMA "M" Flange</i></p> <p><i>Igniter Voltage (nominal): 24Vdc</i> <i>Voltage range: 21.6V - 32V</i> <i>Current: 1.2 Amps</i> <i>Ign. Secondary: 19kVpk 35mA</i> <i>Interrupted OR intermittent duty</i></p> <p><i>Valve Coil Voltage: 24 Vdc</i> <i>Current: < 0.5A</i></p>
Pump	<i>Outlet pressure: Note 1</i>
Dimensions	<p><i>Height (maximum): 11 ½ inches</i> <i>Width (maximum): 14 3/8 inches</i> <i>Depth (chassis only): 6 9/16 inches</i> <i>Air tube diameter: 4 inches</i></p>
Ambient Operating Temperature	<p>+32° F. (0° C.) Minimum +115° F. (+46° C.) Maximum (See Warning on Impaired Burner Performance and Fire Hazard.)</p>

*Firing rate capacity is based on airflow volume. In the ADC burner, airflow volume and motor speed are proportional to the DC voltage. This results in a lower maximum firing rate at 24V.

Note 1. See equipment manufacturer's burner specifications for recommended outlet pressure. Pressure is 100 psig unless otherwise noted.

NOTICE

High altitude installations – Accepted industry practice requires no derate of burner capacity up to 2,000 feet above sea level. For altitudes higher than 2,000 feet, derate the burner capacity 2% for each 1,000 feet above the 2,000 feet.

General Information

Refer to the Troubleshooting section of this manual when experiencing a possible fault condition.

A. Equipment Located in Confined Space

The confined space should have two permanent openings: one near the top of the enclosure and one near the bottom of the enclosure. Each opening shall have a free area of not less than one square inch per 1,000 BTU's per hour of the total input rating of all equipment within the enclosure. The openings shall have free access to the building interior, which should have adequate infiltration from the outside.

B. Exhaust Fans and Other Air-Using Devices.

Size air openings large enough to allow for all air using devices in addition to the minimum area required for combustion air. If there is any possibility of the equipment room developing negative pressure (because of exhaust fans, for example), either pipe combustion directly to the burner or provide a sealed enclosure for the burner and provide it with its own combustion air supply.

C. Clearances to Burner and Equipment

Provide space around burner and equipment for easy service and maintenance. Check minimum clearances against those shown by the equipment manufacturer and by applicable codes.

Table 2 – Air Tube Combination (ATC) Codes

Firing Rate GPH	Head	Static Plate Size inches	ATC Codes for Usable Air Tube Lengths: (‘A’ in inches see Fig. 2)		
			4-1/2	5-3/8	6-5/8
0.75 - 1.25	F3	2-3/4	AF44XNDC	AF53XNDC	AF65XNDC
0.85 - 1.35	F4	2-3/4	AF44WHDC	AF53WHDC	AF65WHDC
0.85 - 1.65	F6	2-3/4	AF44YBDC	AF53YBDC	AF65YBDC
1.10 - 2.00	F12	2-3/4	AF44XODC	AF53XODC	AF65XODC
1.65 - 2.50	F22	2-3/4	AF44XPDC	AF53XPDC	AF65XPDC
2.50 - 3.00	F31*	2-3/4	AF44XVDC	AF53XVDC	AF65XVDC

*See page 3 for capacity and voltage specifications.



Adequate Voltage Required

A low or erratic power supply could result in impaired burner operation, severe delayed ignition or an explosion inside the heat exchanger resulting in a burn and/or asphyxiation hazard.

- The Model ADC requires a continuous supply of 21.6 to 28 volts DC measured at the burner during operation with a minimum supply & circuit capacity of 15A. See page 3 for maximum capacity and voltage specifications.
- An automotive or small engine charging system that is capable of supplying the required continuous voltage/amperage is recommended with certain road equipment, such as asphalt hot patchers and similar applications.
- This is especially true while maintaining nominal load temperatures during idle periods.
- Once the burner is set-up at a specific voltage, a voltage regulator shall be used to maintain that voltage within +/- 1 Vdc during burner operation.



Adequate Combustion and Ventilation Air Supply Required

Failure to provide adequate air supply could seriously affect the burner performance and result in damage to the equipment, asphyxiation, explosion or fire hazards.

- The burner cannot properly burn the fuel if it is not supplied with a reliable combustion air source.
- Follow the guidelines in the latest editions of the NFPA 31 and CSA-B139 regarding providing adequate air for combustion and ventilation.

Table 1 – Low Firing Rate Baffle

Head Type	Low Firing Rate Baffle (if specified)
F3	up to 0.85 gph
F4 or F6	up to 0.90gph

Figure 1 – Typical Burner Nameplate

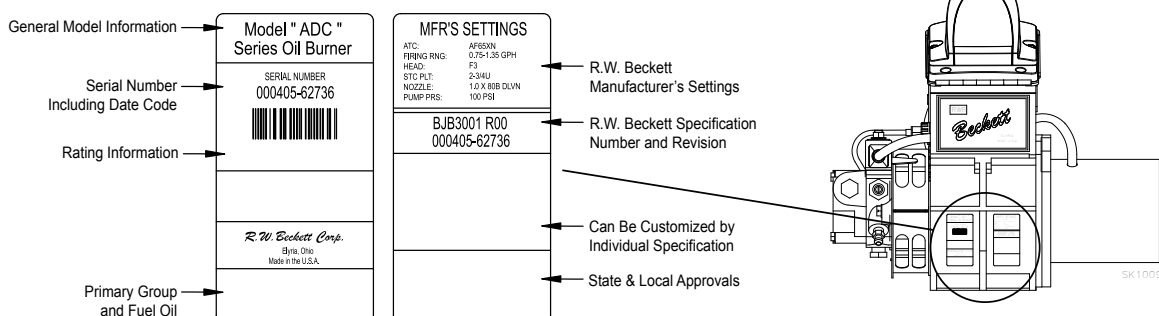

D. Exhausting Hazardous Fumes

See warning on this page. Also be conscious of any fumes produced by the materials that are being heated. Always ensure adequate ventilation to exhaust all fumes.

E. Low Firing Rate Baffle.

The low firing rate baffle (See LFRB in Replacement Parts) reduces the air flow and pressure. The LFRB is sometimes used for firing rates under 1.00 gph as listed in **Table 1**. Refer to the equipment manufacturer's instructions. Do not omit the LFRB when specified. Omitting the baffle when specified or installing the baffle when not specified could result in poor burner performance.

Nozzle Assembly Maintenance



WARNING

Correct Nozzle and Flow Rate Required



Incorrect nozzles and flow rates could result in impaired combustion, under-firing, over-firing, sooting, puff-back of hot gases, smoke and potential fire or asphyxiation hazards.

Use only nozzles having the brand, flow rate (gph), spray angle and pattern specified by the appliance manufacturer.

Follow the appliance manufacturer's specifications for the required pump outlet pressure for the nozzle, since this affects the flow rate.

- Nozzle manufacturers calibrate nozzle flow rates at 100 psig.
- When pump pressures are higher than 100 psig, the actual nozzle flow rate will be greater than the gph stamped on the nozzle body. (Example: A 1.00 gph nozzle at 140 psig = 1.18 gph)

Securely tighten the nozzle (90 torque inch pounds). For typical nozzle flow rates at various pressures refer to **Table 3 on page 13**.

A. Replace the Burner Nozzle.

1. If applicable, remove the plastic plug protecting the nozzle adapter threads.
2. Place a 3/4" open-end wrench on the nozzle adapter. Insert the nozzle into the adapter and finger tighten. Finish tightening with a 5/8" open-end wrench.
3. If the nozzle is already installed, remove the nozzle line assembly to verify that the nozzle size and spray pattern are correct for the application (per equipment manufacturer's information). Verify that the electrode tip settings comply with **Figure 2**.



CAUTION

Use care when removing or installing an oil nozzle

A damaged nozzle could cause impaired combustion, sooting, puffback of hot gases, oil leakage and potential fire or asphyxiation hazards.

- Inspect the nozzle adapter to insure that the sealing surface is not grooved or scratched.
- To insure that the nozzle functions properly, check the orifice and strainer for dirt, scratches or other damage before installation.
- Do NOT attempt to install or remove a nozzle without securing the adapter to prevent seriously damaging the alignment.
- Use care when handling the nozzle line assembly to prevent changing the electrode tip settings or damaging the ceramic electrode insulators.
- Ensure that the electrode settings match the values shown in **Figure 2**.

Figure 2 – Electrode Tip Setting

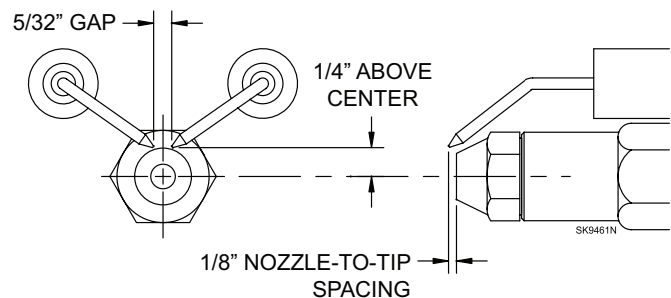

B. Check/Adjust Electrodes

Check the electrode tip settings. Adjust if necessary to comply with the dimensions shown in **Figure 2**. To adjust, loosen the electrode clamp screw and slide/rotate electrodes as necessary. Securely tighten the clamp screw when finished.

C. Igniter Maintenance

The igniter assembly does not require any adjustments beyond making sure the springs and the burner electrode rods make solid contact when the igniter is in the closed position. The sealing surfaces of the gaskets should be checked and replaced at the first signs of any damage or deterioration. Clean any dirt or residue from the porcelain bushings, springs, and baseplate.

The simplest way to check igniter operation is by supplying voltage to the input and checking to see whether an arc is produced. Check by either looking or listening to see if there is an arc across the electrodes while the burner is running and the igniter is energized.

Figure 3 – Igniter Hinge & Retainer Clips

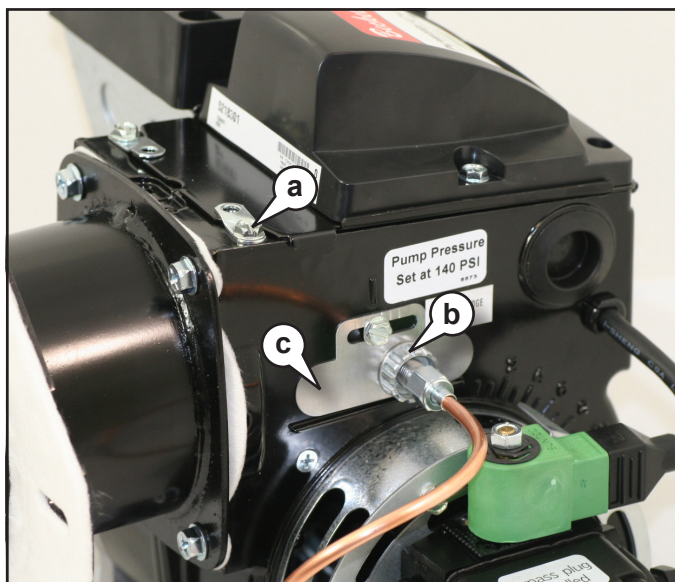

The igniter must be grounded to the burner before checking the following. To check the igniter, ensure all power to the burner is off and use an ohmmeter to check the resistance between the two springs. The meter should read between 480 - 580 ohms.

The igniter should be replaced if the meter indicates an open circuit, or the spring-to-spring resistance exceeds the 480 - 580 ohms range by more than 10%.

D. Servicing Nozzle Line Assembly

Before proceeding, turn off power to the burner.

1. Disconnect the oil connector tube from the nozzle line.
2. Referring to **Figure 3**, loosen the two screws securing the igniter retaining clips (a) and rotate both clips to release the igniter baseplate. Then tilt the igniter back on its hinge.
3. Remove the splined nut (b).
4. Remove the nozzle line assembly from the burner, being careful not to damage the electrodes or insulators while handling. To ease removal of short assemblies, it may be necessary to loosen the escutcheon plate (c). Reset to the edge of the label.
5. To replace the nozzle line assembly, reverse the above steps.

Figure 4 – ‘Z’ Dimensions Using Gauge

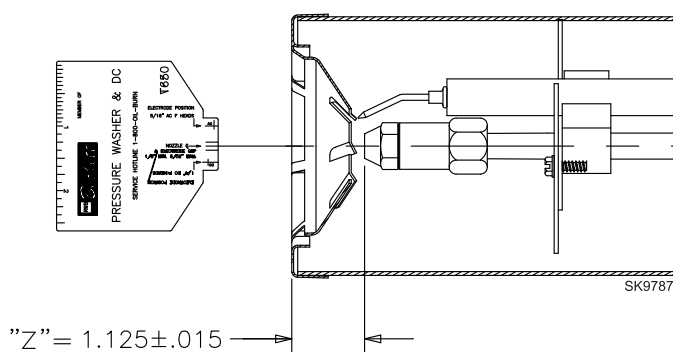

E. Check/Adjust “Z” Dimension

Refer to **Figure 4**. The critical “Z” dimension is the distance from the face of the nozzle to the flat face of the head. This distance for F heads is 1-1/8”. The “Z” dimension is factory set for burners shipped with the air tube installed but should always be verified during service and installation. If the “Z” dimension is out of adjustment, perform the following steps.

Figure 5 – Nozzle, Line & Electrode Assembly

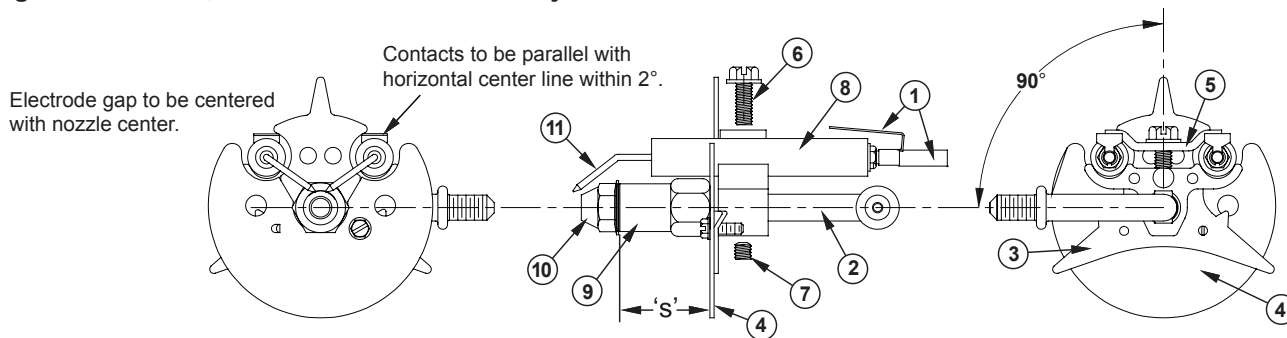

Item #	Description
1	Electrode Contact (3" ATC or extension over 3")
2	Nozzle Line
3	Spider spacer assembly
4	Static Plate
5	Electrode clamp
6	Electrode clamp retaining screws

Item #	Description
7	Nozzle line setscrew
8	Electrode Insulator
9	Nozzle adapter
10	Nozzle tip
11	Electrode tip

Before proceeding, turn off power to the burner.

1. Disconnect the oil connector tube from the nozzle line.
2. Referring to **Figure 5**, loosen the splined nut from the nozzle line. Loosen the hex head screw securing the escutcheon plate to the burner housing.
3. A Beckett T650 gauge should be used to set the Z dimension.
4. Place the end of a ruler at the face of the nozzle and, using a straight edge across the head, measure the distance to the face of the head.
5. Slide the nozzle line forward or back until this dimension for F heads is 1-1/8".
6. Tighten the hex head screw to secure the escutcheon plate to the burner chassis. Then tighten the splined nut and attach the oil connector tube.
7. Recheck the "Z" dimension periodically when servicing to ensure the escutcheon plate has not shifted. You will need to reset the "Z" dimension if you replace the air tube or nozzle line assembly.

NOTICE

The Beckett Z gauge (part number Z-2000) is available to permit checking the F head "Z" dimension without removing the burner.

Fuel Supply

WARNING

Do Not Install Bypass Plug with 1-Pipe System

Failure to comply could cause immediate pump seal failure, pressurized oil leakage and the potential for a fire and injury hazard.

- The burner is shipped without the bypass plug installed.
- Install the bypass plug in two-pipe oil supply systems ONLY.

A. Connect Fuel Lines

For oil supply system specifications for tanks not mounted on machines, carefully follow the pump manufacturer's literature and the latest edition of the National Fire Protection Association (NFPA) 31 standard.

NOTICE

Pumps with automatic bypass do not require a bypass plug. Verify by referring to the pump manufacturer's instructions.

B. Fuel Supply Level with or Above Burner

The burner may be equipped with a single stage pump. If a one-pipe system is installed, verify a bypass plug is not installed in the pump, then connect the fuel supply

to the burner with a single supply line. Note that manual bleeding of the pump is required on initial start-up or when the equipment runs out of fuel. When connecting a two-pipe fuel system, install the pump bypass plug.

C. Fuel Supply Below Level of Burner

CAUTION

Oil Supply Pressure Control Required

Damage to the filter or pump seals could cause oil leakage and a fire hazard.

- The oil supply inlet pressure to the burner **cannot exceed 3 psig**.
- Ensure that a pressure limiting device is installed in accordance with the latest edition of NFPA 31.
- **Do NOT install valves in the return line.** (NFPA 31, Chapter 8.)
- **Gravity Feed Systems:** Always install an anti-siphon valve in the oil supply line or a solenoid valve (RWB Part # 22246U) in the pump/nozzle discharge tubing to provide backup oil flow cut-off protection.

When the fuel supply is more than eight feet below the level of the burner, a two-pipe fuel supply system is required. Depending on the fuel line diameter and the horizontal and vertical length, the installation may also require a two-stage pump. Consult the fuel unit manufacturer's literature for lift and vacuum capability.

D. Fuel Line Replacement (Remote Tank Only)

When replacing fuel lines, continuous lengths of heavy wall copper tubing is recommended. To ensure a tight seal, always use flare fittings. Never use compression fittings. Always install fittings in an accessible location. To avoid vibration noise, fuel lines should not run against the appliance or the ceiling joists.

E. Fuel Line Valve and Filter

CAUTION

Do Not Use Teflon Tape

Damage to the pump could cause impaired burner operation, oil leakage and appliance soot-up.

- Never use Teflon tape on fuel oil fittings.
- Tape fragments can lodge in fuel line components and fuel unit, damaging the equipment and preventing proper operation.
- Use oil-resistant pipe sealant compounds.

Shutoff valves should be located in the oil supply line. Do not install valves in the return line.

Burner Wiring



Explosion, Fire, Scald, & Burn Hazard



All heating equipment must have HIGH LIMIT controls to protect against excessive temperature and/or pressure. The control must interrupt electrical power and shutdown the burner, if operating or safety controls fail and cause a runaway condition.

- Follow the equipment manufacturer’s wiring diagrams and note all required safety controls.
- Typical safety controls include high temperature or pressure limits, low water cutoffs, pressure relief valves and blocked flue sensing switches.
- Verify all limit and safety controls are installed and functioning correctly, as specified by the manufacturer, applicable safety standards, codes and all authorities having jurisdiction.
- Ensure the equipment is free of oil and oil vapor before starting or resetting the burner.
- **Do not wire power directly to the burner motor. Only wire the motor as shown in Figure 6. If instant burner heat is required by the application, purchase or program a control with a long motor-off delay time, which will ensure instant heat if a new call for heat is received within the motor-off delay time.**



WARNING Electrical Shock Hazard

Electrical shock can cause severe personal injury or death.

- Remove all jewelry, such as rings and watches before performing service.
- Disconnect electrical power before installing or servicing the burner.
- Provide ground wiring to the burner, metal control enclosures and accessories. (This may also be required to aid proper control system operation.)

A. Burner installed on equipment

Refer to appliance manufacturer’s wiring diagram for electrical connections. Refer to “Maintain & Service Burner” section near the end of this manual.

B. Burner Replacement

Burner wiring may vary, depending on the actual primary control and furnished options. Refer to **Figure 6** for typical burner wiring.

Figure 6 – Wiring with 7559 Control

Notes:

1. Wires are to be sized to prevent a voltage drop between the battery and the burner with the burner running at full load.
2. Fuse Sizes (inside control): Motor = 20 Amp; Igniter, Control, Valve, & Alarm = 7.5 Amp
3. Hard-wire burner ground to battery. Do NOT use chassis ground system.
4. Input power to the control’s +24 volt wire shall be provided from a fused service switch, rated at 50 amps or less.
5. Motor-off delay on a 7559P will be disabled if the safety and operating limits (as shown in this figure) interrupt power to the control’s red +24 volt wire.
6. Do not wire power directly to the burner motor. Only wire the motor as shown in this figure. If instant burner heat is required by the application, purchase or program a control with a long motor-off delay time, which will ensure instant heat if a new call for heat is received within the motor-off delay time.

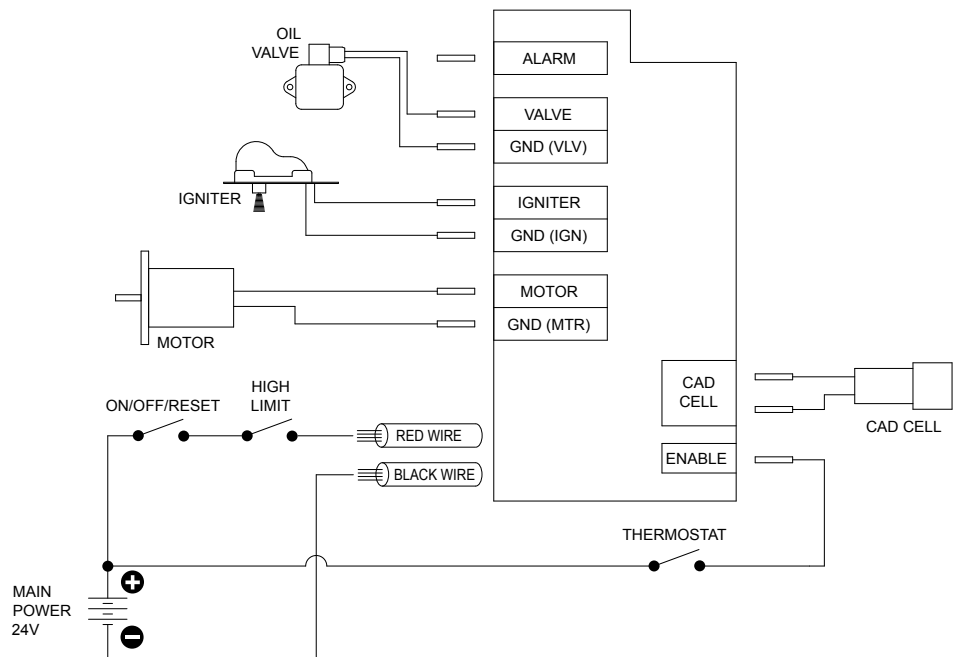

Drive Component Maintenance

A. Motor, Blower Wheel, and Coupling Replacement

The motor will require replacement if the proper voltage is measured at the motor input, and the motor will either not run, or the current draw with a free running pump exceeds 10% of the rated current.

To replace the burner motor, coupling and/or blower wheel perform the following steps.

1. Before servicing, turn off and/or disconnect all power to the burner.
2. Disconnect the burner motor wires.
3. Remove the bolts securing the motor to the burner housing.
4. Remove the motor, coupling, and blower wheel.
5. Loosen the set screw on the blower wheel to slide the existing wheel off the shaft.
6. Slide the new blower wheel onto the old shaft (after thoroughly cleaning housing) and/or slide the old blower wheel onto the new motor shaft.
7. Place a .030" (1/32" \pm 1/64") feeler gauge between the blower wheel and the motor housing.
8. Slide the blower wheel toward the motor until it contacts the feeler gauge.
9. Rotate the blower wheel until the setscrew is centered on the flat of the motor shaft. Tighten the setscrew to secure the wheel.
10. Slide the motor coupling on the motor shaft, then

install the motor on the burner housing. Ensure that the motor coupling fits between the motor shaft and the pump shaft inside the housing. Tighten the motor retaining screws. Reconnect the wires.

11. Restore power, start the burner and perform the combustion test described previously in this manual.

B. Pump Maintenance

General Pump Information

Important information - Long or oversized inlet lines may require the pump to operate dry during initial bleeding period. In such cases, the priming may be assisted by injecting fuel oil in the pump gear set. Under lift conditions, lines and fittings must be air tight. To assure this, "Pipe Dope" may be applied to both the used and unused inlet and return fittings. **Do NOT use Teflon tape or compression fittings**

Mounting Position - Beckett CleanCut pump may be mounted in any position (except upside-down in a single pipe installation).

Vacuum Check - A Vacuum Gauge may be installed in either of the 1/4" NPT inlet ports.

Pressure Check - When a pressure check is made, use the nozzle port. If the bleed port is used, the reading on the gauge should be approximately 5 psig higher than the pressure reading on the nozzle port. See **Figure 8**.

Cutoff Check - To check cutoff pressure dead head a pressure gauge in the nozzle port. Run the burner for a short period of time. Shut the burner off. The pressure will drop and hold above zero. Pressurized or gravity feed installations must not exceed 3 psig on inlet line or return line at the pump per NFPA 31. A pressure greater than 10 psig may cause damage to the shaft seal.

Figure 7 – Blower Wheel

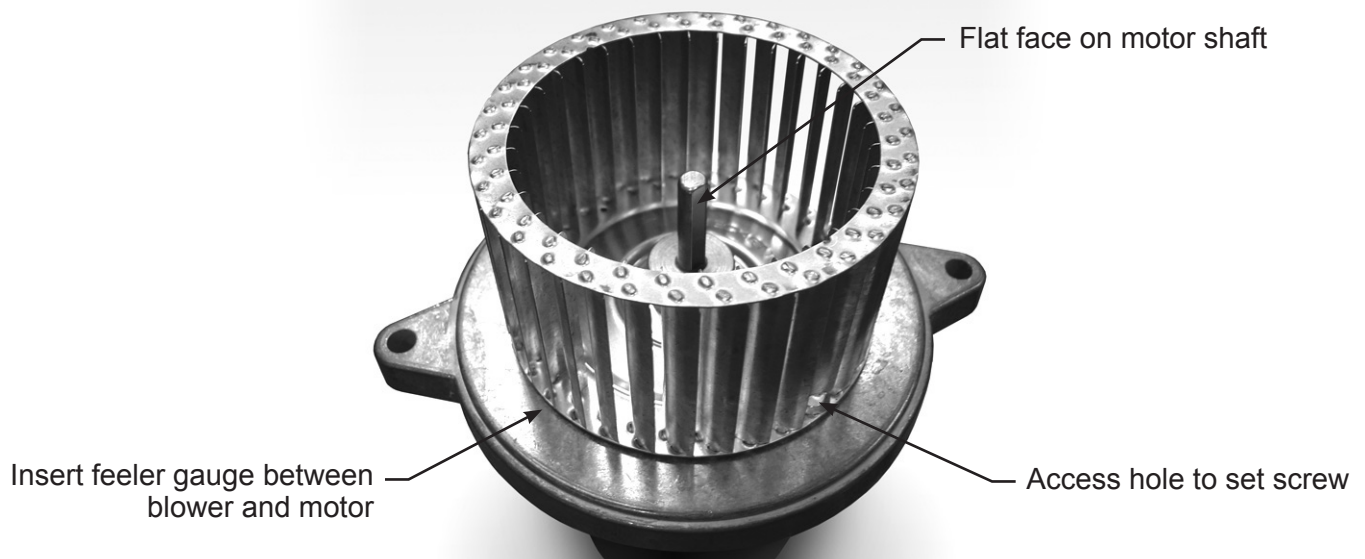

C. Valve Coil and Stem Replacement

To determine if the valve coil requires replacement perform the following steps.

1. Remove the cord set from the valve.
2. Place the leads from an ohmmeter across the coil.
3. A 24Vdc volt coil should measure between 60 and 75 ohms.
4. If the meter indicates an open circuit, replace the coil.

To check pump operation perform the following.

1. Check the operating pressure by removing the copper tubing from the nozzle line and installing a pressure gauge in the line. With the motor running and the coil energized, check the gauge. The pressure should read 100 psig unless otherwise stated.
2. To check the cutoff function, deadhead the pressure gauge onto the copper connector tube attached to the nozzle port. Run the burner for a short period of time. Shut the burner off; the pressure should drop and hold.

To replace the coil and/or pump assembly perform the following steps.

1. Before servicing, turn off and/or disconnect all power to the burner.
2. Remove the copper tube assembly when replacing the pump or when removing the coil and the tube blocks the coil.
3. Using a flat tip screwdriver, press the flat tip into the spring washer to prevent it from rotating.
4. Using a 10mm wrench or adjustable wrench, remove the nut and spring washer.
5. Remove the coil by lifting it straight up.
6. Remove the two base plate screws, then the base plate by lifting straight up.
7. Remove valve stem assembly by pulling straight up.
8. To install the new stem and coil assemblies, follow the above steps in reverse order, tightening each part as you go.
9. Restore power, start the burner and perform the combustion test described previously in this manual.

Figure 8 – Pump and Valve Assemblies

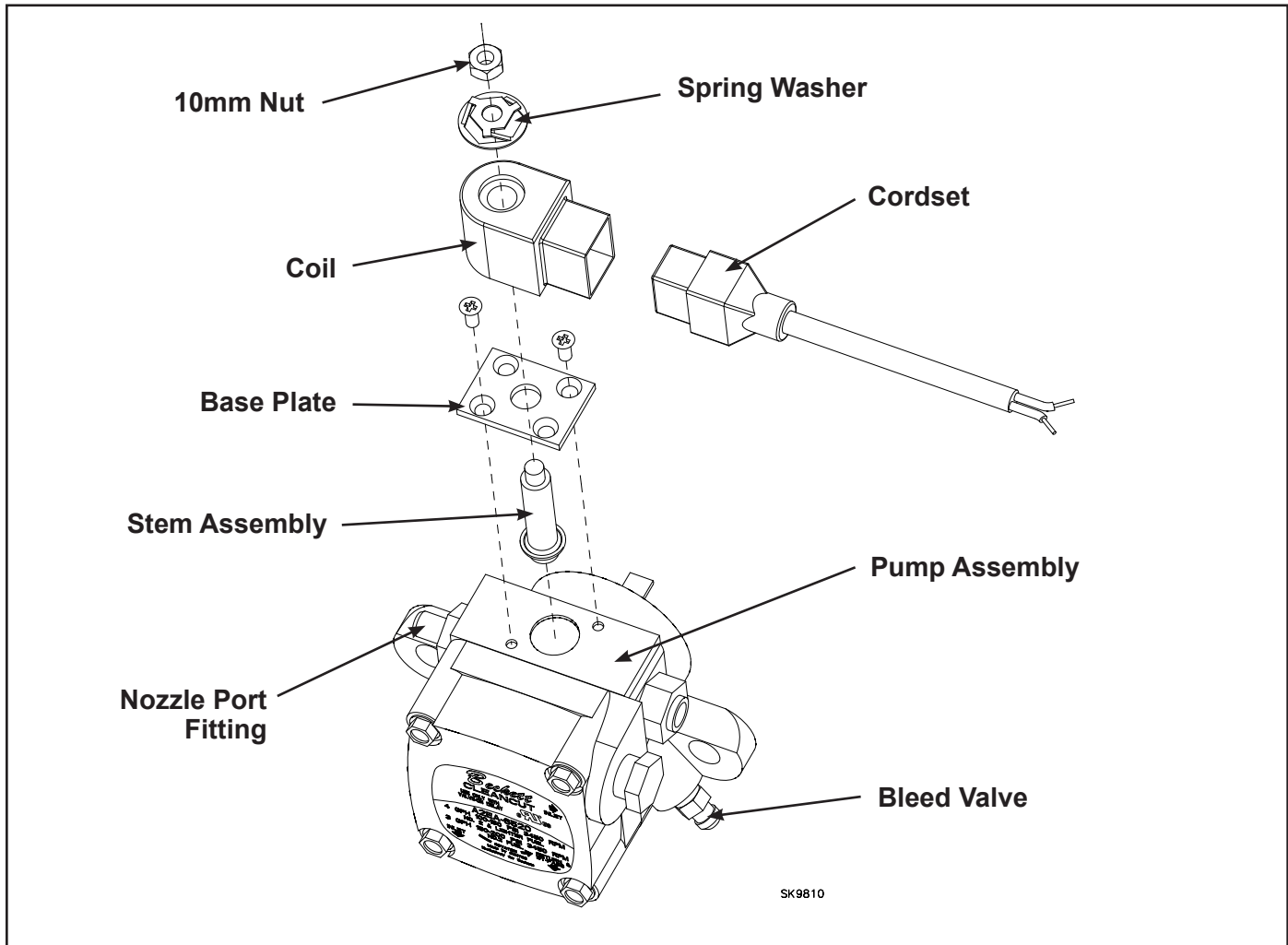

Start Up Burner & Set Combustion

A. Basic Burner Operation

With 7559 Control - The 7559 control provides the benefits of added safety, convenience, and performance. It adds a valve on delay and motor-off delay to the burner's operation sequence that promote clean burner operation. It has a lock-out function that shuts the burner down if it is not operating properly. The control adds fusing at the burner to protect against component failures. The control also has redundant motor relays that are checked for proper operation every heat cycle.

Variations to the burner circuits may occur due to optional temperature, pressure, and vacuum switches that control burner operation. Note that when external switches are used to control motor operation they must be sized correctly for the rated current or a relay should be installed to isolate the switches from the motor's full load current.

B. Combustion Set-up

WARNING

Explosion and Fire Hazard



Failure to follow these instructions could lead to equipment malfunction and result in heavy smoke emission, soot-up, hot gas puff-back, fire and asphyxiation hazards.

- Do not attempt to start the burner when excess oil has accumulated in the appliance, the appliance is full of vapor, or when the combustion chamber is very hot.
- Do not attempt to re-establish flame with the burner running if the flame becomes extinguished during start-up, venting, or adjustment.
- **Vapor-Filled Appliance:** Allow the unit to cool off and all vapors to dissipate before attempting another start.
- **Oil-Flooded Appliance:** Shut off the electrical power and the oil supply to the burner and then clear all accumulated oil before continuing.
- If the condition still appears unsafe, contact the Fire Department. Carefully follow their directions.
- Keep a fire extinguisher nearby and ready for use.

As soon as burner motor starts rotating bleed all the air from the pump. (Required with single-pipe systems.)

To bleed the pump, attach a clear plastic hose over the vent fitting. Loosen the fitting and catch the oil in an empty container. Tighten the fitting when all air has been

purged from the supply system. Note: If the burner stops after a flame is established, the unit probably requires additional bleeding. Continue to bleed the system until the pump is primed and a flame is established when the bleed valve is closed.

C. Set Combustion with Instruments

1. Allow the burner to run for approximately 5 to 10 minutes.
2. Follow these four steps to properly adjust the burner:
 - Step 1: Adjust the air until a trace smoke level is achieved.
 - Step 2: At the trace of smoke level, measure the CO₂ (or O₂). This is the vital reference point for further adjustments.
 - Step 3: Increase the air to reduce CO₂ by 1 percentage point (O₂ will be increased by approximately 1.4 percentage points).
 - Step 4: Recheck the smoke level. It should be zero.
3. This procedure provides a margin of reserve air to accommodate variable conditions.
4. Once the combustion level is set, tighten the fasteners on the air band and air shutter.
5. Start and stop the burner several times to ensure satisfactory operation.
6. Test the equipment safety controls to verify they function according to the manufacturer's specifications.

Figure 9 – Air supply components

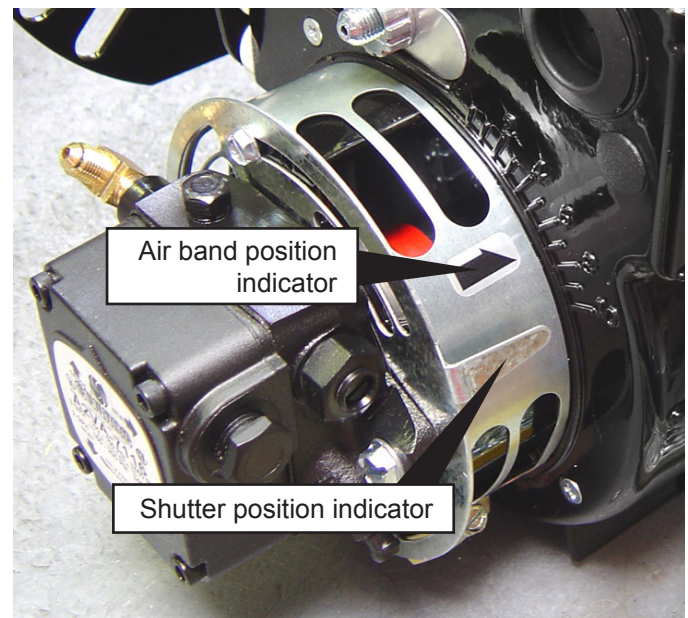

Maintain & Service Burner

A. Owner's Information



WARNING Professional Service Required



Incorrect installation, adjustment, and use of this burner could result in severe personal injury, death, or substantial property damage from fire, carbon monoxide poisoning, soot or explosion.

Please read and understand the manual supplied with this equipment. This equipment must be installed, adjusted and put into operation only by a qualified individual or service agency that is:

- Licensed or certified to install and provide technical service to oil heating systems.
- Experienced with all applicable codes, standards and ordinances.
- Responsible for the correct installation and commission of this equipment.
- Skilled in the adjustment of oil burners using combustion test instruments.

The installation must strictly comply with all applicable codes, authorities having jurisdiction and the latest revision of the National Fire Protection Association Standard for the installation of Oil-burning Equipment, NFPA 31 (or CSA-B139 and CSA-B140 in Canada). Regulation by these authorities take precedence over the general instructions provided in this installation manual.

Have your equipment inspected at regular intervals by a qualified service agency to assure continued proper operation. The burner should be adjusted using dedicated combustion test equipment. Failure to properly set the burner could result in inefficient operation, and/or conditions that could potentially cause severe personal injury, death or substantial property damage.

B. Owner Service and Maintenance

Properly installed and maintained, your ADC burner will provide years of efficient, trouble-free operation. Please take care of your equipment by following the warnings provided and by immediately contacting your qualified service agency if your burner is not operating properly.

This equipment should be serviced only by a qualified service agency. The appropriate test instruments must be used.

Daily

Check the area around your burner/equipment to make sure:

- Nothing is blocking the burner inlet air openings.
- Air ventilation openings are clean and unobstructed and the exhaust is not crusted.
- No combustible materials are stored near the equipment.
- There are no signs of oil or water leakage around the burner or equipment.

Extended Down Time

If the equipment will be stored for an extended period of time, insure that the fuel tank is full and add a fuel stabilizer to the tank.

Regular Service/Maintenance



WARNING Use only Beckett replacement parts for continued safe operation of the burner.

Have your burner, serviced annually by your qualified service agency. The following components/assemblies should be checked/adjusted/replaced on a regular basis. Refer to the Replacement Parts exploded view for part locations.

- Replace the oil supply line filter, if applicable. The line filter cartridge must be replaced to avoid contamination of the pump and nozzle.
- Inspect the oil supply system. All fittings should be leak-tight. The supply lines should be free of water, sludge and other restrictions.
- Remove and clean the pump strainer.
- Verify the nozzle is the one originally specified by the appliance manufacturer and replace the nozzle with one having the exact specifications from the same manufacturer.
- Clean and inspect the electrodes for damage, replacing any that are cracked or chipped.
- Check electrode tip settings. Replace electrodes if tips are rounded.
- Inspect the igniter spring contacts. Clean or replace if corroded.

- Clean the cad cell, if applicable.
- Make sure Low Firing Rate Baffle is in place, if required, for the burner application. Omitting the baffle can result in unacceptable burner combustion.
- Inspect all gasket including the igniter base plate gasket. Replace any that are damaged or missing.
- Clean the blower wheel, air inlet, air guide, retention head and static plate of any dirt, asphalt or other material.
- Check motor current. The amp draw should not exceed the nameplate rating. Check all wiring for loose connections or damaged insulation.
- Check the pump pressure and cutoff function.
- Check primary control safety lockout timing, if applicable. Refer to the information supplied by the control manufacturer for procedures.
- Check ignition system for proper operation.
- Inspect the exhaust system for soot accumulation or other restriction.
- Clean the equipment thoroughly according to the manufacturer's recommendations.
- Check the burner performance using test instruments.
- It is good practice to make a record of the service performed and the combustion test results.

Table 3 – Nozzle Flow Rate by Size

Nozzle flow rate U. S. gallons per hour of No. 2 fuel oil when pump pressure (psig) is:					
Nozzle Size (rated at 100 psig)	125 psi	140 psi	150 psi	175 psi	200 psi
0.40	0.45	0.47	0.49	0.53	0.56
0.50	0.56	0.59	0.61	0.66	0.71
0.60	0.67	0.71	0.74	0.79	0.85
0.65	0.73	0.77	0.80	0.86	0.92
0.75	0.84	0.89	0.92	0.99	1.06
0.85	0.95	1.01	1.04	1.13	1.20
0.90	1.01	1.07	1.10	1.19	1.27
1.00	1.12	1.18	1.23	1.32	1.41
1.10	1.23	1.30	1.35	1.46	1.56
1.20	1.34	1.42	1.47	1.59	1.70
1.25	1.39	1.48	1.53	1.65	1.77
1.35	1.51	1.60	1.65	1.79	1.91
1.50	1.68	1.77	1.84	1.98	2.12
1.65	1.84	1.95	2.02	2.18	2.33
1.75	1.96	2.07	2.14	2.32	2.48
2.00	2.24	2.37	2.45	2.65	2.83
2.25	2.52	-	-	-	-

Troubleshooting

Oil burners that are designed for use on road maintenance equipment are built to take temperature extremes, vibration, and rough handling. When performing the following troubleshooting steps, we assume that the oil burner motor and ignition transformer operate continuously and the oil solenoid valve, which controls oil flow, is cycled by the equipment controls. We also assume that there is power to the burner and fuel in the tank.

In addition to typical mechanics tools, it is recommended to have the following equipment on hand.

- Meter capable of measuring volts, ohms and amps,
- ignition transformer tester,
- smoke pump tester,
- combustion analyzer, and
- 0 to 200 psi pressure gauge.

See **Table 4** on following page for troubleshooting steps.

Table 4 – Troubleshooting Chart

Symptom	Possible Cause
Oil Not Igniting	<p>If the burner is not igniting, the burner motor, drive coupling, and oil pump are operating and oil is flowing to the nozzle through the solenoid valve, check the following possibilities.</p> <ol style="list-style-type: none"> 1. Check the air shutter adjustment. If the air shutter is opened too far, the flow of air may prevent the arc from reaching the oil spray. This may appear as a white vapor exhaust from the heater. [Refer to section “Start up burner and set combustion”] 2. The ignition system may have failed to supply an adequate arc to ignite the oil. Check the battery and charging system to insure a continuous supply of 21.6 to 28 volts DC (15 amps). [Refer to section “Nozzle Assembly Maintenance”] 3. Check the electrodes for wear and damage. Insure that the electrodes are adjusted properly. [Refer to section “Nozzle Assembly Maintenance”]
No Flame	<p>If there is no flame, the burner motor and igniter operate continuously and the oil solenoid valve is functional, check the following possibilities.</p> <ol style="list-style-type: none"> 1. Check for a plugged oil nozzle. [Refer to section 3] 2. If the coil on the solenoid valve is actuating, insure that the valve is opening or closing properly. [Refer to section “Fuel Supply”] 3. Check for sufficient fuel pressure. Pressure is 100 psig with valve energized, unless otherwise noted. [Refer to section “Drive Component Maintenance”] 4. Check the pump pressure. Check for air in fuel lines. 5. Check burner for broken motor coupling. If the coupling is broken check pump rotation prior to replacing the coupling. [Refer to section “Drive Component Maintenance”] 6. Check for contaminated fuel and/or partially plugged fuel filter. [Refer to section “Fuel Supply”]
Motor Not Operating	<p>If the blower motor is not operating, check the following possibilities.</p> <ol style="list-style-type: none"> 1. Check voltage at the motor to insure that switches and relays, in line with the motor, are operating properly. [Refer to section “Burner Wiring”] 2. Check pump and motor shaft operation. They should work freely without binding. [Refer to section “Drive Component Maintenance”]
No Oil Spray	<p>If the blower motor is operating, there is fuel in the tank, but oil does not spray out the end of the nozzle, check the following possibilities.</p> <ol style="list-style-type: none"> 1. Check for a broken or stripped coupling between the pump and the motor. [Refer to section “Drive Component Maintenance”] 2. Check the pump output for oil. [Refer to section “Drive Component Maintenance”] 3. Check operation of the oil valve. [Refer to section “Drive Component Maintenance”] 4. Check for a plugged nozzle. [Refer to section “Nozzle Assembly Maintenance”] 5. Check for air in the oil line. [Refer to section “Nozzle Assembly Maintenance”] 6. Check for fuel contamination or plugged filter. [Refer to section “Nozzle Assembly Maintenance”]
Fluctuating or No Pump Pressure	<p>If the pump pressure, as determined by a pressure gauge, is erratic or does not exist, check the following possibilities.</p> <ol style="list-style-type: none"> 1. Check motor rotational speed. Low rpm can cause erratic or no pump pressure. [Refer to section “Drive Component Maintenance”] 2. Check for a broken or worn motor coupling. [Refer to section “Drive Component Maintenance”] 3. Check that the pump turns freely. [Refer to section “Drive Component Maintenance”] 4. Check for air leaks in the lines. [Refer to section “Fuel Supply”] 5. Check for oil froth at the bleed point. [Refer to section “Fuel Supply”] 6. Check voltage at the motor. [Refer to section voltage rating on nameplate] 7. Check for fuel contamination or partially plugged filter.
Slow Motor Rotation	<p>If the blower motor is not operating at the rpm’s listed on the nameplate, check the following.</p> <ol style="list-style-type: none"> 1. Check the supply voltage to the motor. [Refer to section voltage rating on nameplate] 2. Check for free operation of the motor shaft and pump assembly. [Refer to section “Drive Component Maintenance”]

Replacement Parts

For best performance specify genuine *Beckett* replacement parts

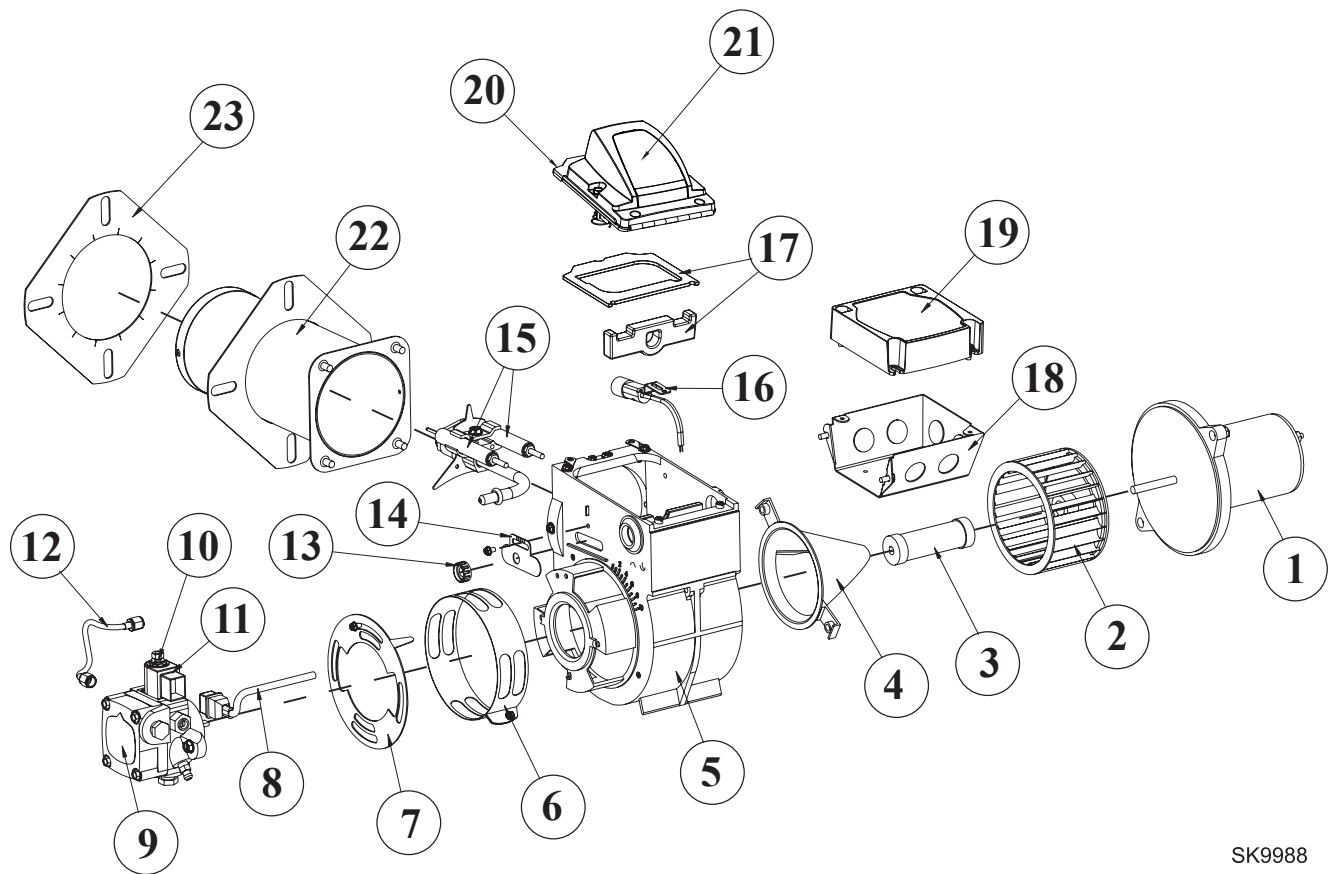

SK9988

Illustration #	Description	Part#
1	DC Motor	21773U
2	Blower Wheel	2999U
3	Coupling	2140501
4	Air Guide	31231U
5	Burner Housing - Black	5874BKU
6	Air Band	5151501
7	Air Shutter - 4 Slot Air Shutter - 8 Slot	3709 3494
8	Cord set	21807
9	Pump (CleanCut)	2184407U
10	Valve Stem	21877U
11	12 Volt Coil	22245U
12	8" Copper Tubing	5394

Illustration #	Description	Part#
13	Escutcheon Plate Spline Nut	3666
14	Escutcheon Plate	3493
15	Electrode Kit over 3-5/8"	578731
16	Cad Cell Detector	7492/7006U
17	Igniter Gasket Kit	51411
18	4X4 Wiring Box Kit	5770
19	Control Kit	7559x-xxxxU*
20	Igniter Assy with baseplate	5218501U
21	Igniter only	5218503U
22	Air Tube Ass'y	Specify
23	Flange Mounting Gasket	Specify
Not Shown	Tune-up Kit for 30 & 35 Air Tube Lengths	578730

* 'X's indicate timing options. Contact Beckett for available part numbers.

Limited Warranty Information

The R. W. BECKETT CORPORATION ("Beckett") warrants to persons who purchase its "Products" from Beckett for resale, or for incorporation into a product for resale ("Customers"), that its equipment is free from defects in material and workmanship. To qualify for warranty benefits, products must be installed by a qualified service agency in full compliance with all codes and authorities having jurisdiction, and used within the tolerances of Beckett's defined product specifications.

To review the complete warranty policy and duration of coverage for a specific product, or obtain a written copy of warranty form 61545, please choose one of the following options:

1. Visit our website at: www.beckettcorp.com/warranty
2. Email your request to: rwb-customer-service@beckettcorp.com
3. Write to: R. W. Beckett Corporation, P. O. Box 1289, Elyria, OH 44036

NOTE: Beckett is not responsible for any labor cost for removal and replacement of equipment.

THIS WARRANTY IS LIMITED TO THE PRECISE TERMS SET FORTH ABOVE, AND PROVIDES EXCLUSIVE REMEDIES EXPRESSLY IN LIEU OF ALL OTHER REMEDIES, AND IN PARTICULAR THERE SHALL BE EXCLUDED THE IMPLIED WARRANTIES OF MERCHANTABILITY AND FITNESS FOR A PARTICULAR PURPOSE. IN NO EVENT WILL BECKETT BE LIABLE FOR ANY INCIDENTAL OR CONSEQUENTIAL DAMAGE OF ANY NATURE. Beckett neither assumes, nor authorizes any person to assume for Beckett, any other liability or obligation in connection with the sale of this equipment. Beckett's liability and Customer's exclusive remedy is limited to the cost of the product.



USA: P.O. Box 1289 • Elyria, Ohio 44036
Canada: R.W. Beckett Canada, Ltd. • Unit #3, 430 Laird Road • Guelph, Ontario N1G 3X7
www.beckettcorp.com