

CONTROL NO.	REV.	DESCRIPTION	BY	DATE	APR
PCO-6996	0	PRODUCTION RELEASE	BPS	03/03/11	RC

DRAWING - RELEASED AND ACTIVE

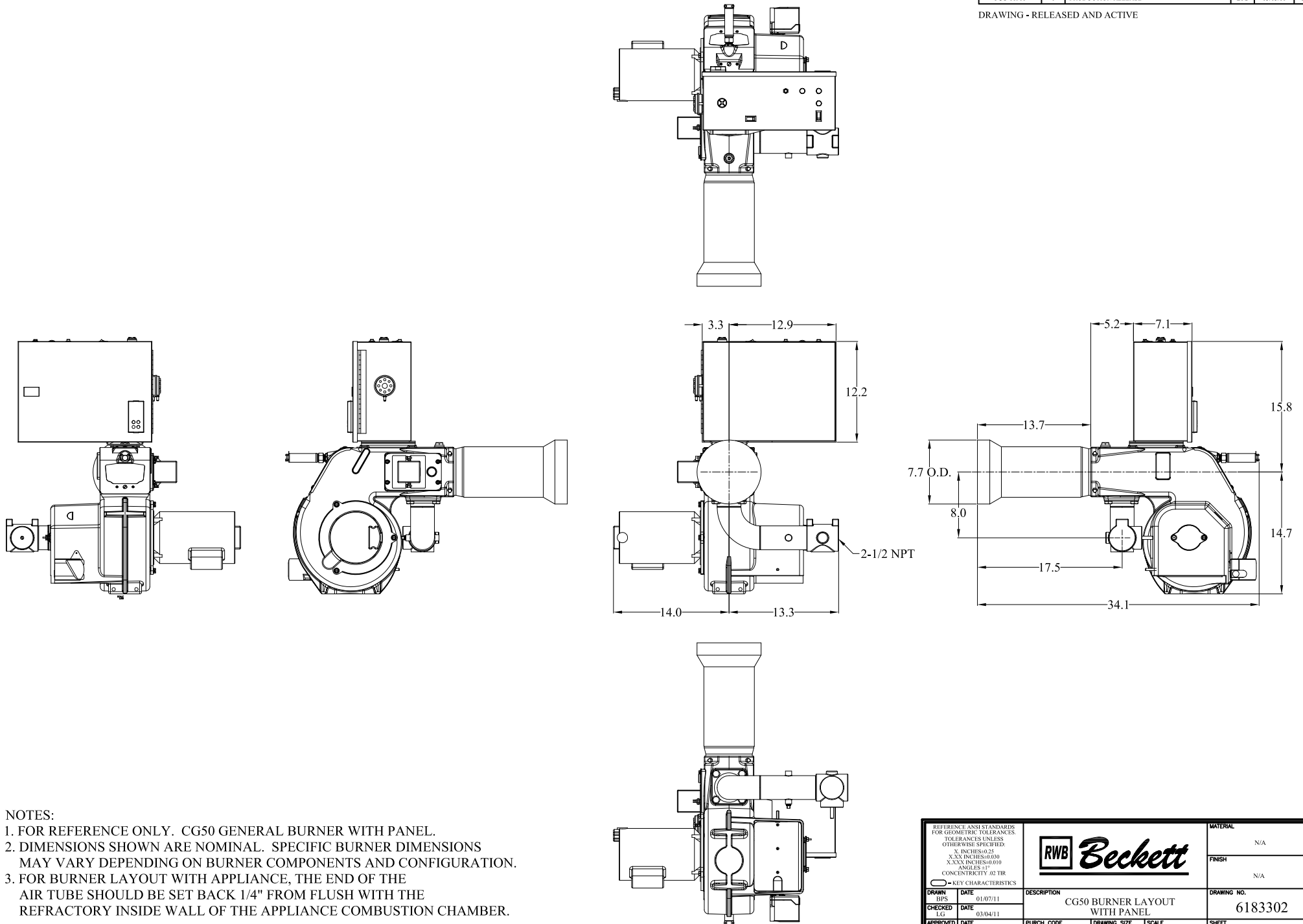

NOTES:

1. FOR REFERENCE ONLY. CG50 GENERAL BURNER WITH PANEL.
2. DIMENSIONS SHOWN ARE NOMINAL. SPECIFIC BURNER DIMENSIONS MAY VARY DEPENDING ON BURNER COMPONENTS AND CONFIGURATION.
3. FOR BURNER LAYOUT WITH APPLIANCE, THE END OF THE AIR TUBE SHOULD BE SET BACK 1/4" FROM FLUSH WITH THE REFRACTORY INSIDE WALL OF THE APPLIANCE COMBUSTION CHAMBER.

DRAWN		DATE	DESCRIPTION	MATERIAL
BPS		01/07/11		
CHECKED	LG	03/04/11	FINISH	N/A
APPROVED	RC	03/03/11	PURCH CODE	DRAWING SIZE
			MAKE	C
			SCALE	NTS
			DRAWING NO.	6183302
			SHEET	1 OF 1