

CF2500/ CF3500

Oil Burner Manual

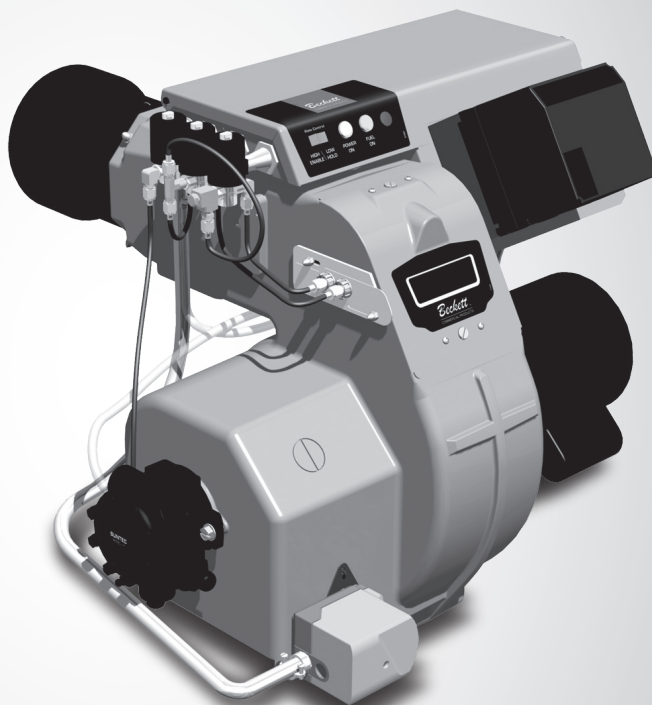

Beckett™

COMMERCIAL PRODUCTS



⚠ WARNING

Potential for Fire, Smoke and Asphyxiation Hazards



Incorrect installation, adjustment, or misuse of this burner could result in death, severe personal injury, or substantial property damage.

To the Homeowner or Equipment Owner:

- Please read and carefully follow all instructions provided in this manual regarding your responsibilities in caring for your heating equipment.
- Contact a professional, qualified service agency for installation, start-up or service work.
- Save this manual for future reference.

To the Professional, Qualified Installer or Service Agency:

- Please read and carefully follow all instructions provided in this manual before installing, starting, or servicing this burner or heating system.
- The Installation must be made in accordance with all state and local codes having jurisdiction.

To the Owner:

Thank you for purchasing a Beckett burner for use with your heating appliance. Please pay attention to the Safety Warnings contained within this instruction manual. Keep this manual for your records and provide it to your qualified service agency for use in professionally setting up and maintaining your oil burner.

Your Beckett burner will provide years of efficient operation if it is professionally installed and maintained by a qualified service technician. If at any time the burner does not appear to be operating properly, immediately contact your qualified service agency for consultation.

We recommend annual inspection/service of your oil heating system by a qualified service agency.

Daily – Check the room in which your burner/appliance is installed. Make sure:

Air ventilation openings are clean and unobstructed

Nothing is blocking burner inlet air openings

No combustible materials are stored near the heating appliance

There are no signs of oil or water leaking around the burner or appliance

Weekly - Check your oil tank level. Always keep your oil tank full, especially during the summer, in order to prevent condensation of moisture on the inside surface of the tank.

NOTICE

Special Requirements - The installation of a burner shall be in accordance with the regulations of authorities having Jurisdiction.

- For recommended installation practices in the U.S. refer to the latest edition of NFPA 31. (CSA-B139 and CSA-B140 in Canada.)

WARNING

Impaired Burner Performance & Fire Hazard

Do NOT operate the burner beyond specifications outlined in the Table on Page 3.

- For applications beyond these limits, consult Beckett Technical Services at 1-800-645-2876.
- NOTE: Some packaged appliances with burners may be agency listed as a unit to operate beyond these limits. Consult the appliance manufacturer's specifications and agency approvals for verification.

Contents

General Information	3
Hazard Definitions	3
Specifications	3
Owner's Responsibility:	3
Service Agency Responsibility:	3
Combustion Air Supply	4
Clearances	4
Fuel Supply	4
Nozzle Pressure	5
Electrical Supply	5
Vent System	5
Verify Burner Components	5
Verify Firing Rate	5
Verify Air Tube	6
Dust and Moisture	7
Mount the Burner	7
Mount Flange(s) on Air Tube	7
Mount Air Tube to Burner	8
Install Nozzle	8
Check Electrode Settings	8
Install Nozzle Line Assembly	8
Set Dimension Z	9
Insert Burner	9
Connect Fuel Lines	10
Fuel Unit By-pass Plug	10
One-pipe Oil System By-pass Loop	10
Oil Supply/Return Lines	10
Burner Fuel Flow	10
Wire the Burner	12
Typical Burner Sequence of Operation - GeniSys 7505	12
Cad Cell Resistance Measurement:	13
Typical Burner Sequence of Operation - RM7897A Control	15
Z Dimension	17
Adjusting Plate Assembly	17
Initial Head Position	17
Initial Air Settings	18
Set Appliance Limit Controls	19
Prepare the Fuel Unit for Air Venting	19
Start the Burner	19
Start Burner and Vent Air from Oil Line	19
Set High-fire Air	20
Set Low-fire Air	20
Perform Regular Maintenance	21
Annual Service — by qualified service technician	21
Monthly Maintenance — by owner	21
Replacement Parts	22
Limited Warranty Information	24

Agency Approvals

- UL listed to comply with ANSI/UL296 and certified to CSA B140.0.
- Accepted by N.Y.C. M.E.A.
- Other approvals may be available and must be specified at time of order.



General Information

Hazard Definitions

DANGER Indicates a hazardous situation which, if not avoided, will result in death or serious injury.

WARNING Indicates a hazardous situation, which, if not avoided, could result in death, or serious injury.

CAUTION Used with the safety alert symbol, indicates a hazardous situation, which, if not avoided, may result in minor or moderate injury.

NOTICE Used to address practices not related to personal injury.

Specifications

Fuels	U.S. #1 or #2 heating oil only (ASTM D396) Canada #1 stove oil or #2 furnace oil only
	CAUTION DO NOT USE GASOLINE, CRANKCASE OIL, OR ANY OIL CONTAINING GASOLINE.
Firing Range	CF2500A - 17.0 to 19.9 gph CF2500 - 17.0 to 25.0 gph CF3500A - 17.0 to 35.0 gph
Motor	2 HP 3450 rpm 208/230/60 Hz Standard 13.4 amps @ 230 VAC Optional Voltages: 208, 230, 480, 575 VAC/3-PH, 50 or 60 Hz
Ignition Trans.	Continuous Duty, 120V/12,000V
Housing	Cast aluminum
Fuel Unit	100 to 300 psig
Oil Nozzle	45° to 70° Solid
Dimensions	Refer to <i>Figure 8</i> .

NOTICE 50 Hz Motors - The burner ratings, air settings and nozzle ratings are based on standard 60 Hz motors (at 3450 rpm). Derate all ratings 20% when using 50 Hz motors. Consult factory for specific application data.

Owner's Responsibility:

WARNING Follow these instructions exactly.

Failure to follow these instructions, misuse, or incorrect adjustment of the burner could result in asphyxiation, explosion or fire.

Contact a professional, qualified service agency for the installation, adjustment and service of your oil burning system. Thereafter, have your equipment adjusted and inspected at least annually to ensure reliable operation. This work requires technical training, trade experience, licensing or certification in some states and the proper use of special combustion test instruments.

- Never store or use gasoline or other flammable liquids or vapors near this burner or appliance.
- Never attempt to burn garbage or refuse in this appliance.
- Never attempt to light the burner by throwing burning material into the appliance.
- Never attempt to burn any fuel not specified and approved for use in this burner.
- Never restrict the air inlet openings to the burner or the combustion air ventilation openings in the room.

CAUTION Frozen Plumbing and Water Damage Hazard

If the facility is unattended in severely cold weather, burner primary control safety lockout, heating system component failures, power outages or other electrical system failures could result in frozen plumbing and water damage in a matter of hours. For protection, take preventive actions such as having a security system installed that operates during power outages, senses low temperature and initiates an effective action. Consult with your heating contractor or security agency.

Service Agency Responsibility:

WARNING Follow these instructions exactly.

Failure to follow these instructions could result in asphyxiation, explosion or fire.

- Please read all instructions before proceeding. Follow all instructions completely.
- This equipment must be installed, adjusted and started by a qualified service agency that is licensed and experienced with all applicable codes and ordinances and responsible for the installation and commission of the equipment.
- The installation must comply with all local codes and ordinances having jurisdiction and the latest editions of the NFPA 31 and CSA-B139 & B140 in Canada.

NOTICE High altitude installation - Accepted industry practice requires no derate of burner capacity up to 2000 feet above sea level. For altitudes higher than 2000 feet, derate burner capacity 2% for each 1000 feet above sea level.

Pre-installation Checklist

Combustion Air Supply

WARNING Adequate Combustion and Ventilation Air Supply Required

Failure to provide adequate air supply could seriously affect the burner performance and result in damage to the equipment, asphyxiation, explosion or fire hazards.

- The burner cannot properly burn the fuel if it is not supplied with a reliable combustion air source.
- Follow the guidelines in the latest editions of the NFPA 31 and CSA-B139 regarding providing adequate air for combustion and ventilation.

The burner requires combustion air and ventilation air for reliable operation. Assure that the building and/or combustion air openings comply with National Fire Protection Standard for Oil-Burning Equipment, NFPA 31.

For appliance/burner units in confined spaces, the room must have an air opening near the top of the room plus one near the floor, each with a free area at least one square inch per 1,000 Btu/hr input of all fuel burning equipment in the room.

For other conditions, refer to the latest edition of NFPA 31 (CSA B1139-M91 in Canada).

If there is a risk of the space being under negative pressure or of exhaust fans or other devices depleting available air for combustion and ventilation, the appliance/burner should be installed in an isolated room provided with outside combustion air.

Clearances

With the burner installed in the appliance, there must be adequate space in front of and on the sides of the burner to allow access and operation. Verify that the clearance dimensions comply with all local codes and with the appliance manufacturer's recommendations.

Figure 1 – Typical Nameplate

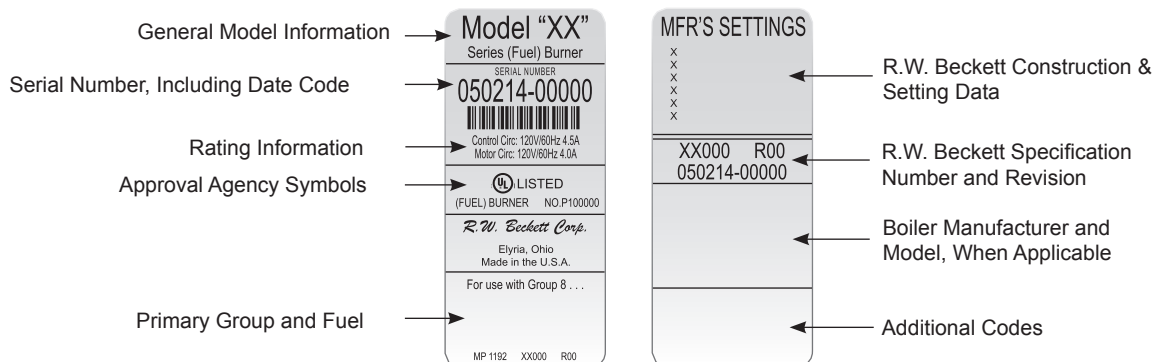

Fuel Supply

CAUTION Oil Supply Pressure Control Required

Damage to the filter or pump seals could cause oil leakage and a fire hazard.

- The oil supply inlet pressure to the burner **cannot exceed 3 psig**.
- Insure that a pressure limiting device is installed in accordance with the latest edition of NFPA 31.
- **Do not install valves in return line.**
- Gravity Feed Systems: Always install an anti-siphon valve in the oil supply line or a solenoid valve (RWB Part # 21789) in the pump/nozzle discharge tubing to provide backup oil flow cut-off protection.

The fuel supply piping and tank must provide #1 or #2 fuel oil at pressure or vacuum conditions suitable for the fuel unit (oil pump) on the burner. Refer to fuel unit literature in the literature envelope in the burner carton to verify allowable suction pressure.

If fuel supply is level with or higher than fuel unit —

- When the fuel unit is not required to lift the oil, the installation is usually suitable for either a one-pipe or two-pipe oil system. The oil pressure at the inlet of the fuel unit must not exceed 3 psig.
- The fuel unit is shipped with the by-pass plug installed. Leave the by-pass plug installed for all low/high firing burners, regardless whether one-pipe (with by-pass loop) or two-pipe. See **Figure 9** for installation of the by-pass loop required for one-pipe fuel supply installations. See **Figure 10** for connections to the fuel unit for two-pipe fuel supply installations.

When fuel supply is below the burner fuel unit —

Use a two-pipe oil system when the fuel unit must lift the oil more than 8 feet. The return line provided by the two-pipe system is needed to minimize the effects of air-related problems during operation.

Nozzle Pressure



Correct Nozzle and Flow Rate Required



Incorrect nozzles and flow rates could result in impaired combustion, under-firing, over-firing, sooting, puff-back of hot gases, smoke and potential fire or asphyxiation hazards.

Use only nozzles having the brand, flow rate (gph), spray angle and pattern specified by the appliance manufacturer.

Follow the appliance manufacturer's specifications for the required pump outlet pressure for the nozzle, since this affects the flow rate.

- Nozzle manufacturers calibrate nozzle flow rates at 100 psig.
- This burner utilizes pressures higher than 100 psig, so the actual nozzle flow rate will be greater than the gph stamped on the nozzle body.
(Example: A 12.00 gph nozzle at 200 psig = 16.97 gph and at 300 psig = 20.78 gph)
- For typical nozzle flow rates at various pressures refer to **Table 1**.

The fuel unit nozzle port pressure is factory set at 300 psig. Some original equipment manufacturer burner applications may call for a lower pressure to obtain a required firing rate. Do not change this pressure unless directed to do so by the appliance manufacturer.

Table 1 - Nozzle Capacities

Rated gph @ 100 psig	Pressure - Pounds per square inch					
	125	150	175	200	250	300
5.00	5.59	6.13	6.61	7.07	7.50	8.66
5.50	6.15	6.74	7.27	7.78	8.70	9.54
6.00	6.71	7.33	7.94	8.48	9.49	10.40
6.50	7.26	7.96	8.60	9.20	10.30	11.25
7.00	7.82	8.56	9.25	9.90	11.06	12.12
7.50	8.38	9.19	9.91	10.60	11.85	13.00
8.00	8.94	9.80	10.58	11.31	12.65	13.85
8.50	9.50	10.45	11.27	12.06	13.40	14.70
9.00	10.06	11.02	11.91	12.73	14.20	15.60
9.50	10.60	11.70	12.60	13.50	15.00	16.45
10.00	11.18	12.25	13.23	14.14	15.81	17.32
10.50	11.74	12.85	13.90	14.85	16.60	18.18
11.00	12.30	13.47	14.56	15.55	17.39	19.05
12.00	13.42	14.70	15.87	16.97	18.97	20.78
12.50	13.98	15.31	16.54	17.68	19.76	21.65
13.00	14.54	15.92	17.20	18.38	20.55	22.52
13.50	15.10	16.53	17.85	19.09	21.34	23.38

Electrical Supply

Verify that the power connections available are correct for the burner. Refer to **Figure 1**. All power must be supplied through fused disconnect switches.

Vent System

The flue gas venting system must be in good condition and must comply with all applicable codes.



Fire, Smoke & Asphyxiation Hazard

- Carefully inspect the chimney or exhaust vent system.
- Make sure it is properly sized and in good working condition.
- Follow the instructions supplied by the appliance manufacturer.
- The installation must strictly comply with all applicable codes, authorities having jurisdiction and the latest revision of the National Fire Protection Association Standard NFPA 31 for the installation of chimneys and vent sizing, (or CSA-B139 and CSA-B140 in Canada).
- Regulation by these authorities take precedence over the general instructions provided in this installation manual.

Verify Burner Components

- **Burner nameplate (Figure 1)**, Model CF2500A/CF2500/CF3500A
- **Air tube assembly**
- **Mounting flange kit**
- **Pedestal mounting assembly kit** (recommended)
- **Oil nozzle**, per **Table 1** — Use only 45° to 70° solid pattern nozzles unless otherwise shown by appliance manufacturer or on the burner nameplate rating label.

The CF2500A, CF2500, and CF3500A are dual nozzle burners. To select the nozzles, use half of the maximum firing rate and select a nozzle under the 300 psig column. Select the corresponding nozzle from column 1 (**Rated gph @ 100 psig**) two nozzles will be required.
Example: a 5.00 gph nozzle at 300 psig = 8.66 gph

Verify Firing Rate

Refer to appliance manufacturer's instructions (if available) for firing rate and nozzle selection. Otherwise, the maximum recommended firing rate for the burner depends on the length of the firing chamber and the distance from the burner center to the chamber floor. Verify that the chamber dimensions are at least as large as the minimum values given in **Figure 2**. If the appliance dimensions are smaller than recommended, reduce the firing rate accordingly.

Figure 2 - Dimensions: Minimum Combustion Chamber and Air Tube Mounting.

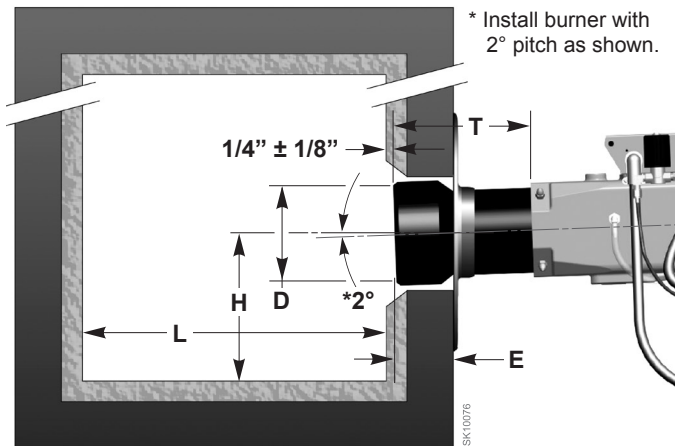

Verify Air Tube

The information in this section may be disregarded if the air tube is supplied by the appliance manufacturer.

The following tube arrangements are available –

- **CF2500** - Tube **KP** -17.0 to 19.9 GPH
- **CF2500A** - Tube **KP** -17.0 to 25.0 GPH
- **CF3500A** - Tube **KM** -17.0 to 35.0 GPH **or** Tube **KR** -17.0 to 35.0 GPH

Maximum firing capacity depends on the firebox pressure. Use **Table 2** to verify the correct air tube type for the firing rate required. (Tube **KR [CF3500A]** is an optional air tube combination for maximum capacity rate. It requires a larger I.D. flange Number 51631.)

See **Figure 2** to verify the correct air tube length and air tube combination code.

Firing Rate (gph)	Minimum Dimensions	
	H	L
17	10.5"	48.0"
22	11.5"	58.0"
27	12.5"	66.0"
32	12.5"	73.0"
35	13.0"	77.0"

Figure 3a - Firebox Pressure: CF2500A with no Reserve Air

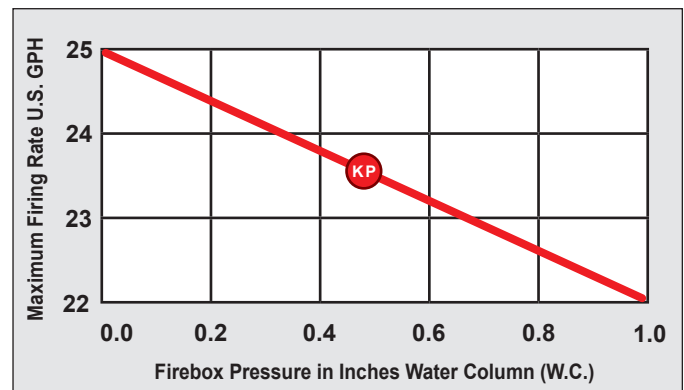

Air Tube Combination Codes					
Model	Tube	Dimension T	Dimension D	Code	Dimension E
CF2500A CF2500	KP	6-3/4"	6-1/2"	CF 66 KP	3-1/4"
		10-1/4"	6-1/2"	CF 102 KP	3-1/4"
		13-3/4"	6-1/2"	CF 136 KP	3-1/4"
		17-3/4"	6-1/2"	CF 176 KP	3-1/4"
CF3500	KM	8"	8"	CF 80 KM	4-1/2"
		9-1/4"	8"	CF 92 KM	4-1/2"
		11-1/2"	8"	CF 114 KM	4-1/2"
		15"	8"	CF 150 KM	4-1/2"
		19"	8"	CF 190 KM	4-1/2"
	KR	11-1/2"	9-15/16"	CF 114 KR	5-1/8"
		14"	9-15/16"	CF 140 KR	5-1/8"
		19"	9-15/16"	CF 190 KR	5-1/8"

Figure 3b - Firebox Pressure: CF3500 with no Reserve Air

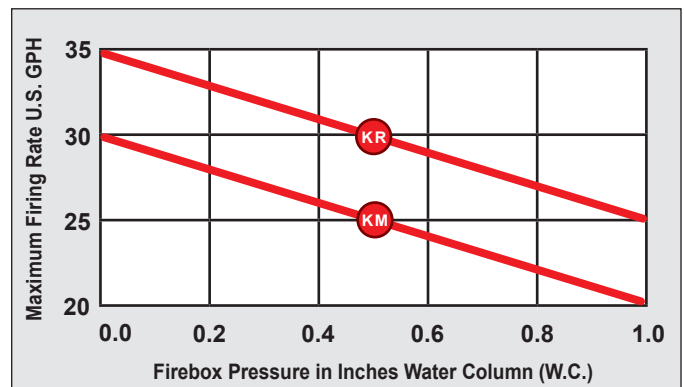

Table 2 - Air Tube Capacity Versus Firebox Pressure

Model	Tube	Maximum Firing Rate GPH		
		Firebox Pressure (In W.C.)	No Reserve Air	10% Turndown (GPH)
CF2500 & CF2500A	KP	0.0	25.0	22.5
		0.2	24.8	22.3
		0.4	24.6	22.3
		0.6	24.5	22.1
		0.8	24.3	21.9
		1.0	24.1	21.7
CF3500A	KM/ KR	0.0	35.0	31.5
		0.2	33.5	30.2
		0.4	32.0	28.8
		0.6	30.2	27.2
		0.8	28.8	25.9
		1.0	27.1	24.4

Note: 10% turndown indicates sufficient reserve air to reduce the CO₂ in the flue to 90% of its value.

Note: The above ratings may vary 5% due to variations in actual job conditions.

Stray Light

NOTICE

Protect Against Stray Light Lockout. Failure to follow these instructions could cause loss of burner operation resulting in no heat, an unplanned process interruption, work stoppage and the potential for frozen plumbing or other cold weather property damage.

- The control must detect a dark, no-flame condition in order to start the burner or it will hold in the stray light lockout mode.
- Shield the burner view window from direct exposure to intense light.

Dust and Moisture

WARNING

Protect Against Dust and Moisture

Wet, dusty environments could lead to blocked air passages, corrosion damage to components, impaired combustion performance and result in asphyxiation, explosion or fire.

- This burner is designed for clean, dry installations.
- Electrical controls are not protected against rain or sprayed water.
- Keep the installation clear of dust, dirt, corrosive vapors, and moisture.
- Protective covers and more frequent maintenance may be required.

Mount the Burner

CAUTION

Protect the Air Tube From Overheating

Overheating could cause damage to the air tube and other combustion components leading to equipment malfunction and impaired combustion performance.

- The end of the air tube must not extend into the combustion chamber unprotected unless it has been factory-tested and specified by the appliance manufacturer.
- Position the end of the air tube 1/4" back from flush with the refractory inside entry wall to prevent damage from overheating.

Mount Flange(s) on Air Tube

This section does not apply to burners with welded flanges.

- Do not install air tube on burner.
- For non-pressure firing flange, refer to **Figure 4**: Install gasket (item **a**) and flange (item **c**). Ignore the next paragraph.
- For pressure-firing flange, refer to **Figure 4**: Slide gasket (item **a**) onto the air tube, making sure the top of the air tube is up. Predrill holes in the pressure firing plate (item **b**) to match the appliance studs. Slide the pressure firing plate (item **b**) and flange (item **c**) onto the air tube as shown. Wrap ceramic fiber rope (not shown) around the air tube and press tightly into the inside diameter of the flange (item **c**).
- Slide the air tube (item **d**) into position in the appliance front. Tighten the flange-mounting-stud nuts. Set the insertion of the air tube so dimension **G** is 1/4" nominal.
- Pitch the air tube at 2° from horizontal as shown and secure the flange to the air tube.

Figure 4 – Mount Flange(s) on Air Tube

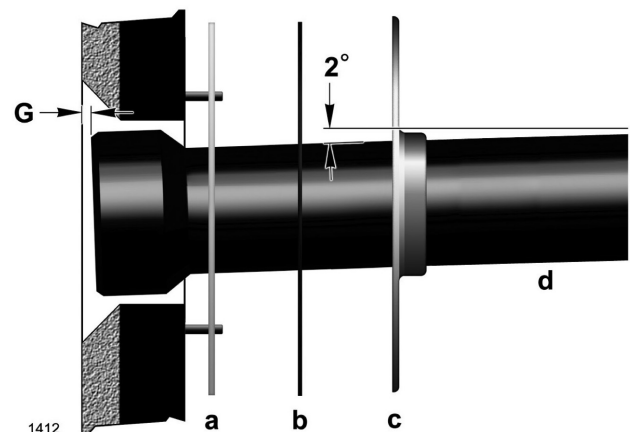

Mount Air Tube to Burner

- Remove the rear access door from the back of the burner for improved access to the interior.
- Attach the air tube to the burner with the bolts and acorn nuts provided. The acorn nuts must go on the outside of the burner, with the bolts inserted from the inside.

Install Nozzle

See **Figure 5**. Install the oil nozzle in the nozzle adapter. Use a $3/4$ " open-end wrench to steady the nozzle adapter and a $5/8$ " open-end wrench to turn the nozzle. Tighten securely but do not overtighten.

Check Electrode Settings

WARNING Maintain Electrode Specifications

Failure to properly maintain these specifications could cause ignition malfunction, puff-back of hot gases, heavy smoke, asphyxiation, explosion and fire hazards.

Check, and adjust if necessary, the critical dimensions P, Q, R and S shown in **Figure 5**. Verify that the oil tube assembly and electrodes are in good condition, with no cracks or damage.

Install Nozzle Line Assembly

- Insert the nozzle line assembly into the burner air tube as in **Figure 6**.
- See **Figures 6 and 7**. Assemble the adjusting plate assembly per the instructions in the assembly packet.
- Slide the secondary adjusting plate (item **f**) completely to the left on the indicator adjusting plate (item **e**). Finger-tighten acorn nut (item **c**) to secure the two plates together. Slide both plates completely to the left on the primary adjusting plate (item **g**) and finger-tighten acorn nut (item **d**).
- Slide the completed adjusting plate assembly over the nozzle line end. Move the plate assembly and the nozzle line so the plate assembly fits into position as shown in **Figure 6**.
- Install the spline nut (**Figure 6**, item **b**) on the end of the nozzle line, leaving the nut loosely placed so the plates can be moved.
- Connect the high-voltage leads from the ignition transformer to the electrodes.

Figure 5 – Nozzle and Nozzle Line Assembly

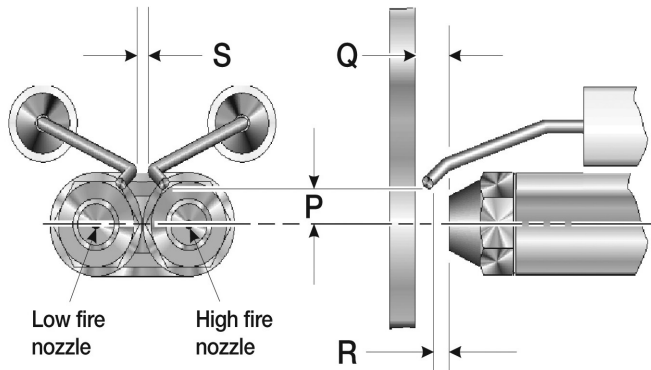

Legend for Critical Dimensions

- P** Nozzle centerline to electrode tip - $1/4$ "
- Q** Nozzle to head - $1/4$ "
- R** Nozzle face to electrode tip - $1/8$ "
- S** Electrode spacing - $3/32$ "

Figure 6 – Nozzle Line Assembly in Burner

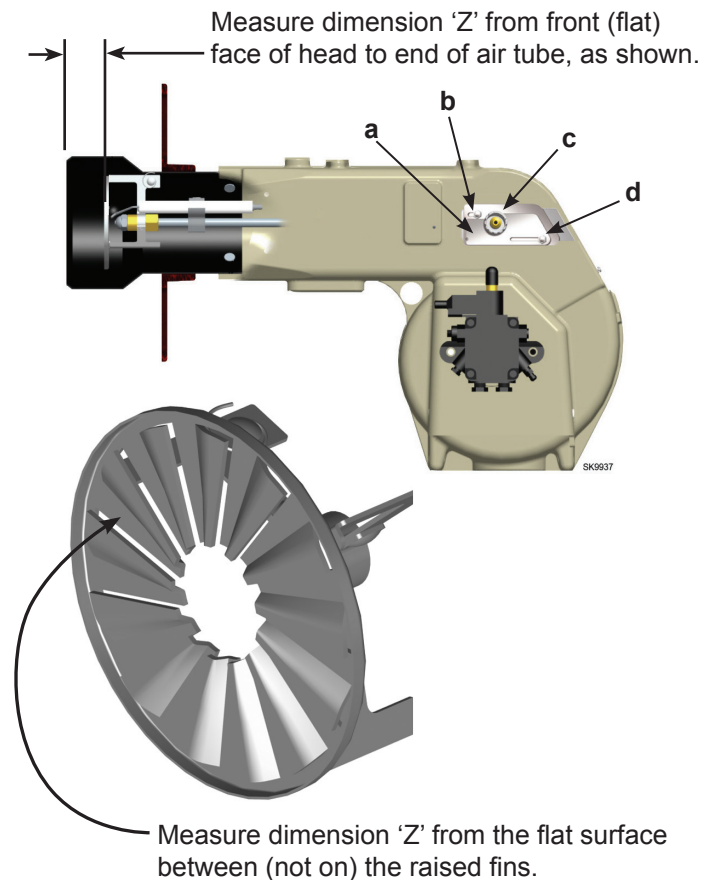

Z Dimensions

- CF2500A/CF2500 = $1-3/4 \pm 1/16$ "
- CF3500A (tube KM) = $2-5/8 \pm 1/16$ "
- CF3500A (tube KR) = $3-9/16 \pm 1/16$ "

Figure 7 – Adjusting Plate Assembly

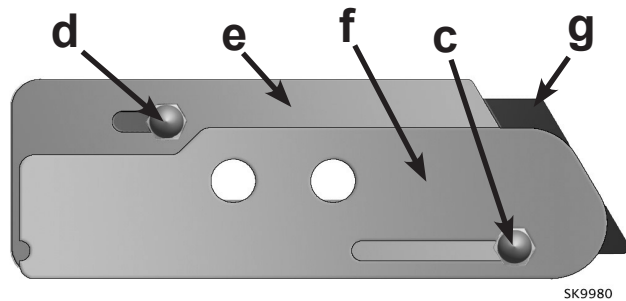
**Legend (Figures 6 & 7)**

- a** Adjusting plate assembly
- b** Spline nut for securing nozzle line
- c** Bottom acorn nut
- d** Top acorn nut (for setting dim. Z only)
- e** Indicator adjusting plate
- f** Secondary adjusting plate
- g** Primary adjusting plate

Set Dimension Z

- Replace the rear access door on the burner, making sure that the adjusting plate assembly is now securely in the groove.
- Loosen acorn nut (item **d**) in **Figure 6**. Slide the nozzle line and plate assembly until dimension Z in **Figure 6** is:
 - CF2500A/CF2500 = 1-3/4" ±1/16"**
 - CF3500A (tube KM) = 2-5/8" ±1/16"**
 - CF3500A (tube KR) = 3-9/16" ±1/16"**
- When dimension Z (from end of air tube to flat area of front face of head) is correctly set, tighten acorn nut (item **d**). Verify that the adjusting plate assembly is properly seated in the groove.
- Attach the oil line from the oil valve to the nozzle line end. Tighten securely.
- Before proceeding, check dimension Z once again. Loosen acorn nut (item **d**) if necessary to reposition the nozzle line. Once dimension Z is set, **do not loosen acorn nut** (item **d**) again.

Insert Burner

- Position the burner in the front of the appliance and loosely tighten the nuts on the mounting studs. The burner should be pitched downward 2° as shown in **Figures 3 and 4**.
- See **Figure 8**. Install the pedestal support kit (recommended) by attaching the 3/4" NPT flange (item **a**) to the bottom of the burner using the (4) #10 screws provided. Cut and thread (one end only) a 3/4" pipe nipple (item **b**) with length 11 inches less than dimension **D** in **Figure 8**. Thread the pipe into the flange.
- Secure the burner to the appliance by tightening the nuts on the burner flange mounting studs.

Figure 8 – Burner Installed in Appliance Front

Legend

Description	Inches
H Housing total length	20"
J Center to bottom of housing	14-1/2"
K Overall housing height	22-3/4"

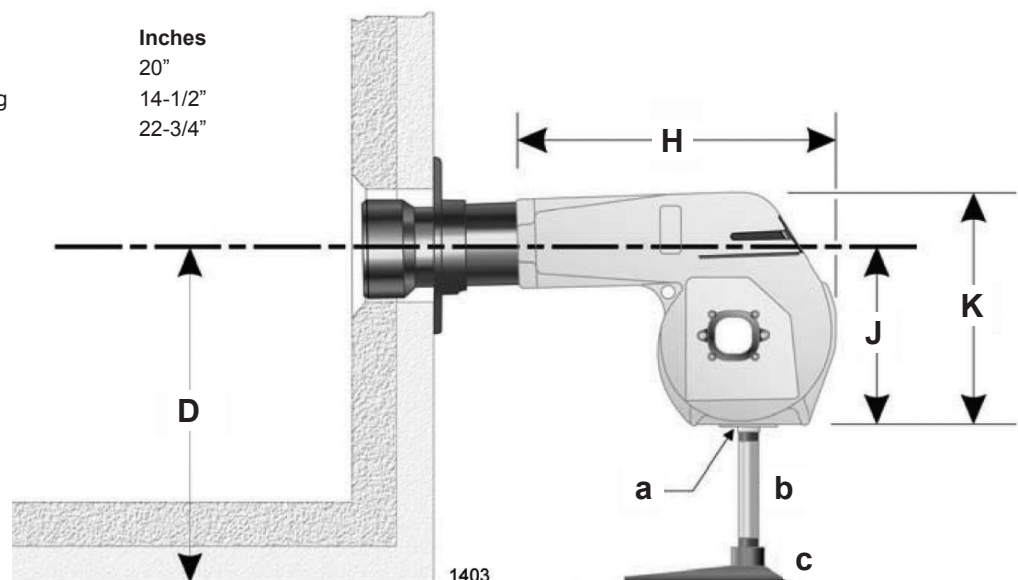

Connect Fuel Lines

Fuel Unit By-pass Plug

WARNING Factory-Installed Pump Bypass Plug

Failure to follow these guidelines will cause the fuel pump seals to rupture and result in oil leakage, burner malfunction and potential fire and injury hazards.

- Models CF2500A/CF2500/CF3500 are shipped with the pump by-pass plug installed.
- Do not remove the by-pass plug from the pump. It is required for step-firing (Lo/Hi) operation.
- Do not operate the burner unless a return line or by-pass loop is installed or the pump seal will rupture.
- Carefully comply with the following instructions provided in this section of the manual.

WARNING Install Oil Supply To Specifications

 *Failure to properly install the oil supply system could cause oil leakage, equipment malfunction, puff-back of hot gases, heavy smoke, asphyxiation, explosion and fire hazards.*

- Carefully install the oil supply lines, fittings and components using the guidelines provided in this section.
- The oil supply must comply with the latest edition of NFPA 31 (Canada CSA B139) and all applicable codes.
- **Do NOT install valves in the return line.**
- If the oil supply inlet pressure to the pump exceeds 3 psig or for gravity feed systems, install an oil safety or pressure reducing valve (Webster OSV, Suntec PRV or equivalent).

One-pipe Oil System By-pass Loop

Refer to **Figure 9** (item k). Note the addition of a field-installed by-pass loop (use 3/8" copper tubing) from the fuel unit Return port to the Inlet port. This line is required for low/high operation. It simulates the flow of a two-pipe system at the fuel unit.

Oil Supply/Return Lines

- Install the oil tank and oil lines in accordance with all applicable codes.
- Size the oil supply and return lines using the guidelines given in the fuel unit literature included in the literature envelope. Oil line flow rate will equal the burner rate for one-pipe systems. For two-pipe systems, refer to **Table 3** for the fuel unit gearset capacity - the rate at which fuel is recirculated when connected to a two-pipe system. Size two-pipe oil lines based on this flow rate.
- Use continuous lengths of heavy-wall copper tubing, routed under the floor where possible. Do not attach fuel lines to the appliance or to floor joists if possible. This reduces vibration and noise transmission problems.
- Install an oil filter sized to handle the fuel unit gearset flow capacity (**Table 3**) for **two-pipe systems**. However, size the filter for the firing rate for **one-pipe systems**. Locate the filter immediately adjacent to the burner fuel unit.
- Install two high-quality shutoff valves in accessible locations on the oil supply line. Locate one valve close to the tank. Locate the other valve close to the burner, upstream of the fuel filter.

Burner Fuel Flow

One-pipe systems – See **Figure 9** for the fuel flow paths for high-fire and low-fire operation. Oil supply connects to one of the fuel unit Inlet ports. A field-installed bypass loop (**Figure 9** Item **K**) must be installed.

Two-pipe systems – See **Figure 10** for the fuel flow paths for high-fire and low-fire operation. Oil supply connects to one of the fuel unit Inlet ports. Oil return connects to the fuel unit Return port.

Low-fire/high-fire operation – The fuel unit nozzle port pressure is factory set at 300 psig.

- At high fire, full pressure (300 psig) is applied at both oil nozzles, causing full input.
- At low fire, full pressure (300 psig) is applied at one nozzle, causing reduced input.

Table 3 – Fuel Unit Gearset Capacities

Fuel Unit Model Number	Gearset Capacity (gph)
H5PAN-C100H	79

Figure 9 – One-pipe Oil Flow

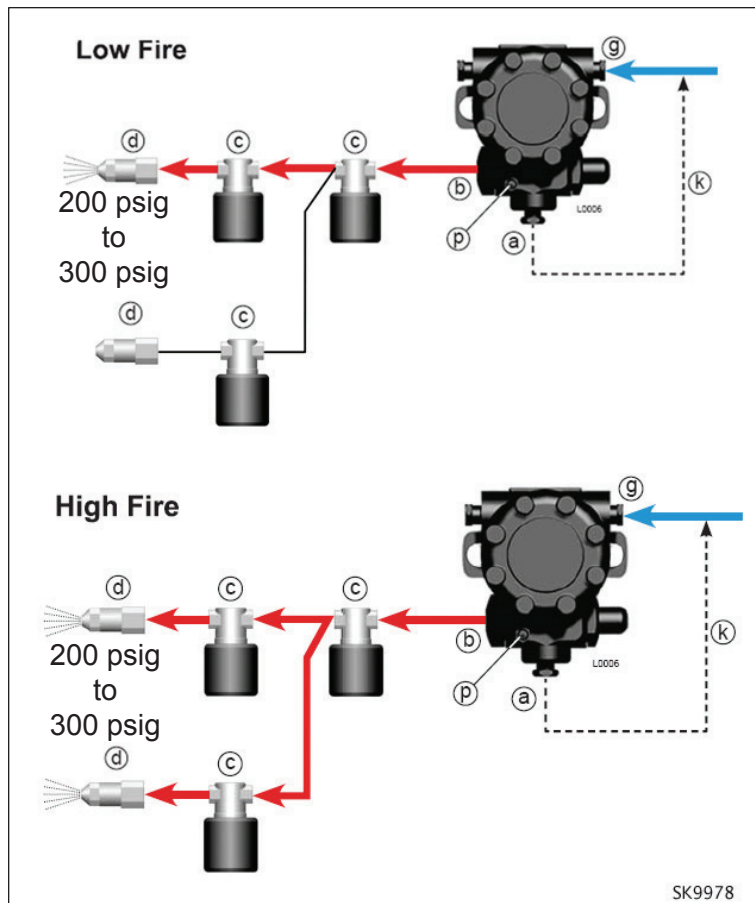

Nozzle Pressure – The fuel unit nozzle port pressure is factory set at 300 psig. Some original equipment manufacturer burner applications may call for a lower pressure to obtain a required firing rate. Do not change this pressure unless directed to do so by the appliance manufacturer.

Figure 10 – Two-pipe Oil Flow

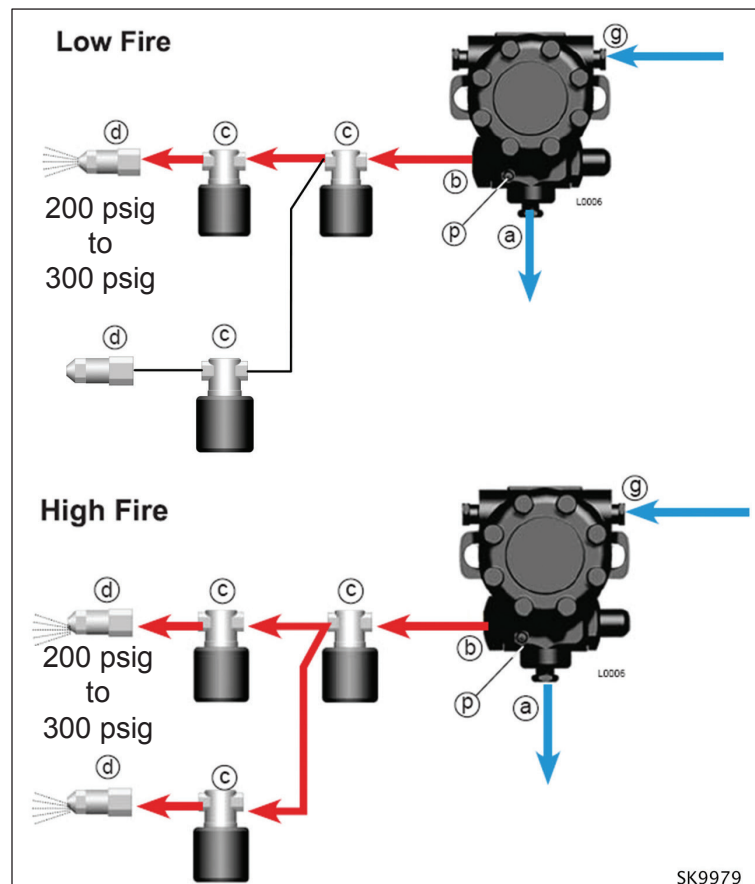

Legend (Figures 9 & 10)

- a Return port
- b Pump outlet
- c Solenoid valve
- d Nozzle
- g Pump inlet
- k By-pass loop
- p Bleed port

Wire the Burner

⚠ WARNING Electrical Shock Hazard

Electrical shock can cause severe personal injury or death.

- Disconnect electrical power before installing or servicing the burner.
- Provide ground wiring to the burner, metal control enclosures and accessories. (This may also be required to aid proper control system operation)
- Perform all wiring in compliance with the National Electric Code ANSI/NFPA 70 (Canada CSA C22.1).

Install the burner and all wiring in accordance with the National Electrical Code and all applicable local codes or requirements.

Wire the burner in compliance with all instructions provided by the appliance manufacturer. Verify operation of all controls in accordance with the appliance manufacturer's guidelines.

See **Figure 11a** (7505P) or **11b** (RM7897A) for a typical wiring diagram (Diagrams are for reference purposes only).

⚠ CAUTION Incorrect Wiring Will Result in Improper Control

Operation

- GeniSys 7505 Control wiring label colors may not match the wire colors of the burner or other manufacturers' controls.
- The GeniSys Control should be wired according to the appliance manufacturer's instructions.

⚠ WARNING Fire or Explosion Hazard

Can cause severe injury, death, or property damage.

- The control can malfunction if it gets wet, leading to accumulation of oil or explosive oil vapors.
- Never install where water can flood, drip or condense on the control.
- Never use a control that has been wet - replace it.

Typical Burner Sequence of Operation - GeniSys 7505

Refer to the appliance manufacturer's wiring diagram for actual specifications. Note: GeniSys 7505 Control on CF2500A only.

1. **Standby:** The burner is idle, waiting for a call for heat.
2. **Valve-On Delay:** The igniter and motor are on while the control delays turning on the oil solenoid valve for the programmed time.

3. **Trial For Ignition:** The oil solenoid valve is energized. A flame should be established within the factory set trial for ignition time (lockout time).
4. **Lockout:** The control has shut down for one of the following safety reasons:

- a. The trial for ignition (lockout) time expired without flame being established.
- b. The cad cell detected flame at the end of the Valve On Delay state.

To reset the control from lockout click the button 1-second.

NOTE: A recurrence of the above failure modes or a failed welded relay check could cause the control to enter a **Hard Lockout** state that must be reset only by a qualified service technician. To reset from Hard Lockout, hold the reset button for 15 seconds until the yellow light turns on.

5. **Ignition Carryover:** Once flame is established, the igniter remains on for 10 additional seconds to ensure flame stability.
6. **Run:** With a flame established and the control continuing to detect a flame, the burner will operate in the RUN mode until the load demand is satisfied or a limit opens.
 - a. If terminals RC1 and RC2 are jumpered, the burner operates in the Low-High-Off Mode. The burner starts at Low, goes to High after the flame stabilization period. Flame is extinguished when the load is satisfied or a limit opens, and the burner is sent to Motor-Off Delay.
 - b. If a high/low control has been wired between terminals RC1 and RC2 the burner starts at Low and is released to go High after the flame stabilization period. It can repeatedly cycle between low and high as necessary to meet load demand until the load is satisfied or a limit opens. The burner is then sent to Motor-off Delay.
7. **Recycle:** If the flame is lost while the burner is firing, the control shuts down the burner, enters a 60 second recycle delay, and repeats the ignition sequence. The control will continue to Recycle each time the flame is lost, until it reaches a pre-set time allotment. The control will then go into Hard Lockout instead of recycle. This feature prevents excessive accumulation of oil in the appliance firing chamber.
8. **Motor-Off Delay:** The oil solenoid valve is turned off and the control delays turning the motor off for the set motor-off delay time before the control returns to standby.
9. **Pump Prime:** The igniter and motor are on with the oil solenoid valve energized for 4 minutes. During Pump Prime mode, the cad cell is disregarded, allowing the technician to prime the pump without having to jumper the cad cell.

Figure 11 - Typical Burner Sequence of Operation - 7505

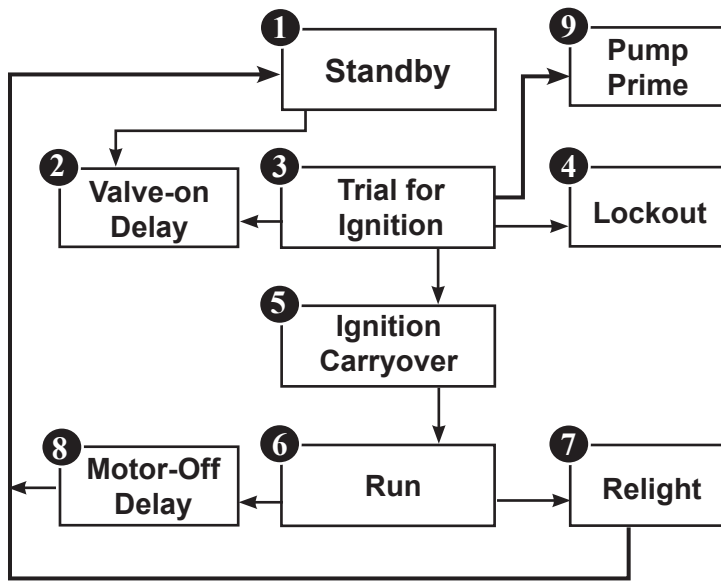

Table 4 - 7505 Flame Detection

Flame Detection Range
Normal = 0 to 1600 ohms
Limited = 1600 ohms to lockout

Cad Cell Resistance Measurement:

If the Beckett 7505 control is equipped with the GeniSys Display Module, part 52067U, the cad cell resistance can be selected and read on the LCD screen. Also, the GeniSys Contractor Tool, part 52082U, can be used for this purpose.

If these are not available, the cad cell leads can be unplugged from the control and the resistance measured with a meter in the conventional way. Conduct these tests with flame present.

Table 5 - 7505 Status Light Explanation Table

Light Color	On Continuously	Flashing
Red	Restricted (Hard) Lockout	Soft Lockout
Green	Flame Sensed during normal operation (Could be stray light during standby)	Recycle
Yellow	Control is in Pump Prime mode or Reset button currently held for 15+ seconds.	N/A

Figure 12 - GeniSys 7505 Control with Optional Components



Optional Components:

Contractor's Tool:
Hand-held device for programming and diagnostics

Display Module:
Permanent device for programming and diagnostics

Alarm Module:
For adding isolated low voltage alarm contacts to the base control. See Alarm Module Instructions for specifications.



Figure 13 – Typical Wiring (7505P)

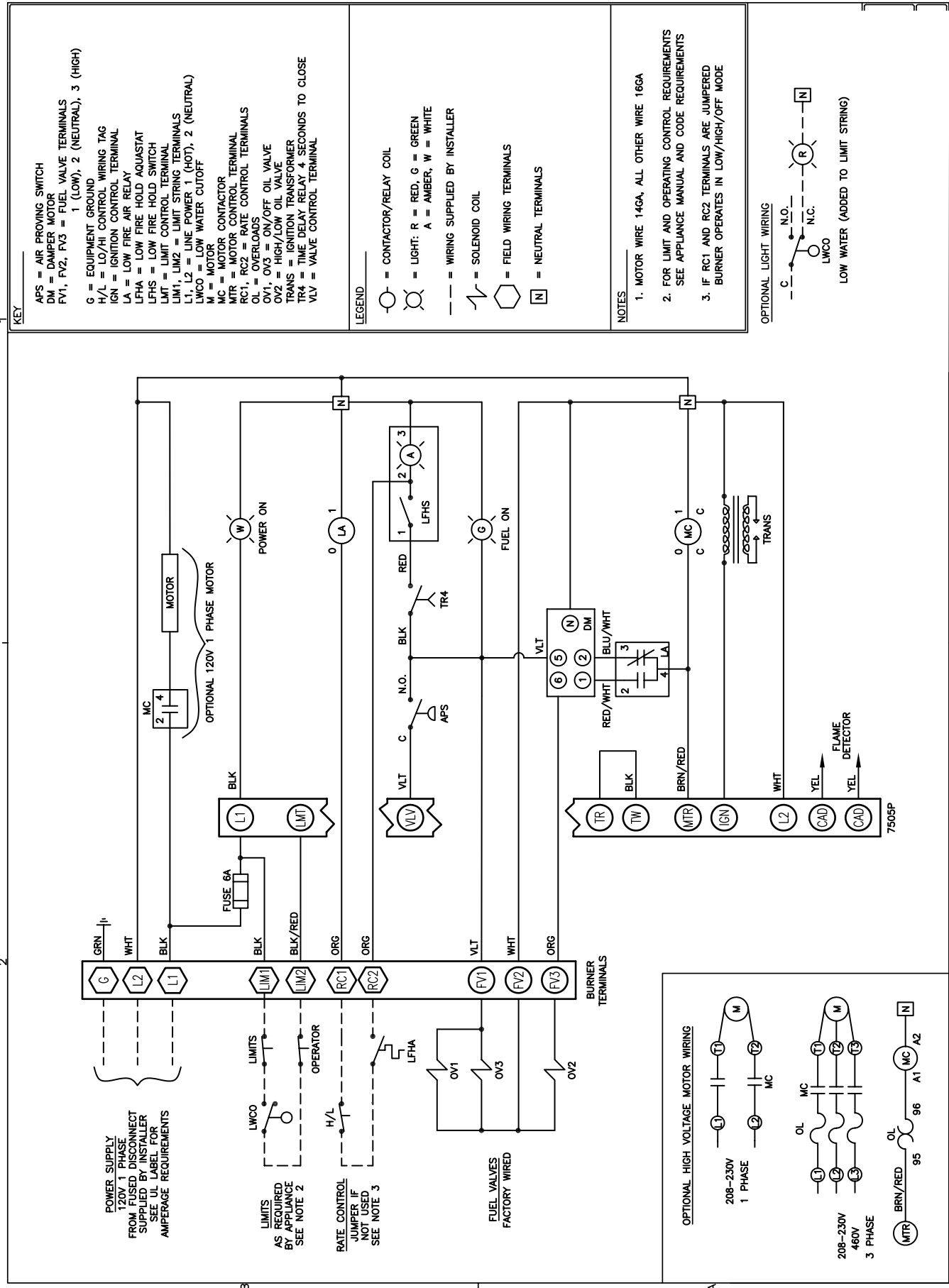

Typical Burner Sequence of Operation - RM7897A Control

When firing over 20 GPH the CF2500 and CF3500A will be supplied with a flame safeguard control. An airflow switch and low-fire start relay will also be supplied. Consult local, state, and federal codes for burner requirements above 20GPH.

Install the burner and all wiring in accordance with the National Electrical Code and all applicable local codes or requirements.

Wire the burner in compliance with all instructions provided by the appliance manufacturer. Verify operation of all controls in accordance with the appliance manufacturer's guidelines.

1. **Initiate** - Power is supplied to the control. The control performs a self-check to ensure proper operation.
2. **Standby** - the burner is idle waiting for a call for heat. When the call for heat is initiated, the burner will proceed to step 3.
3. **Pre-purge** - the burner will begin a 60 second pre-purge to clear the combustion chamber. The burner checks the air flow interlock to see if air is being provided. If the air flow is not present the burner will lockout if jumper JR3 is cut or recycle if the jumper is intact.
4. **Trial for Ignition** - The RM7897A has two trial periods. The first is for light off the second is for main flame establishing. The burner must see flame within 10 seconds if jumper 1 is intact or 4 seconds if jumper 1 is clipped. If the flame is not established, the burner will lockout if jumper 2 is clipped or recycle if the jumper is intact. The burner will then proceed to main flame establishing. If flame is not sensed within 3 seconds the burner will lockout or recycle depending on the status of jumper 2.
5. **Run**: With a flame established and the control continuing to detect a flame, the burner will operate in the RUN mode until the load demand is satisfied or a limit opens.
 - a. If terminals RC1 and RC2 are jumpered, the burner operates in the Low-High-Off Mode. The burner starts at Low, goes to High after the flame stabilization period. Flame is extinguished when the load is satisfied or a limit opens, and the burner is sent to post purge.

- b. If a high/low control has been wired between terminals RC1 and RC2 the burner starts at Low and is released to go High after the flame stabilization period. It can repeatedly cycle between low and high as necessary to meet load demand until the load is satisfied or a limit opens. The burner is then sent to post purge.

6. **Post purge** - The control enters a post purge cycle to clear the combustion chamber of gases. Length of the post purge is factory programmed at 15 seconds.

Figure 14 - Typical Burner Sequence of Operation - RM7897A

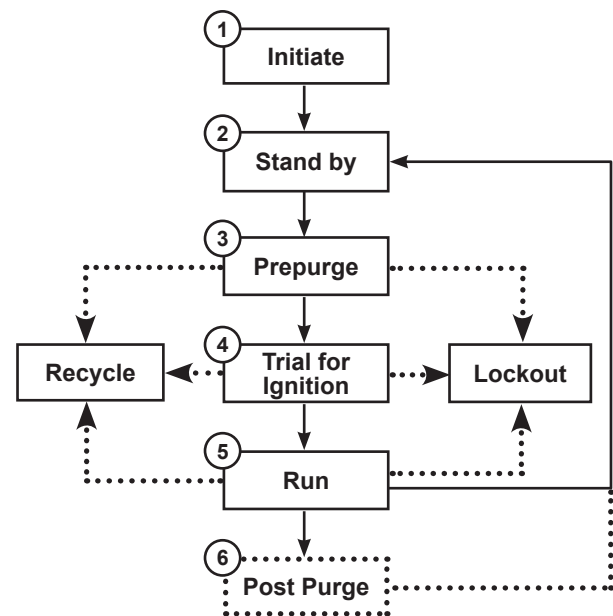
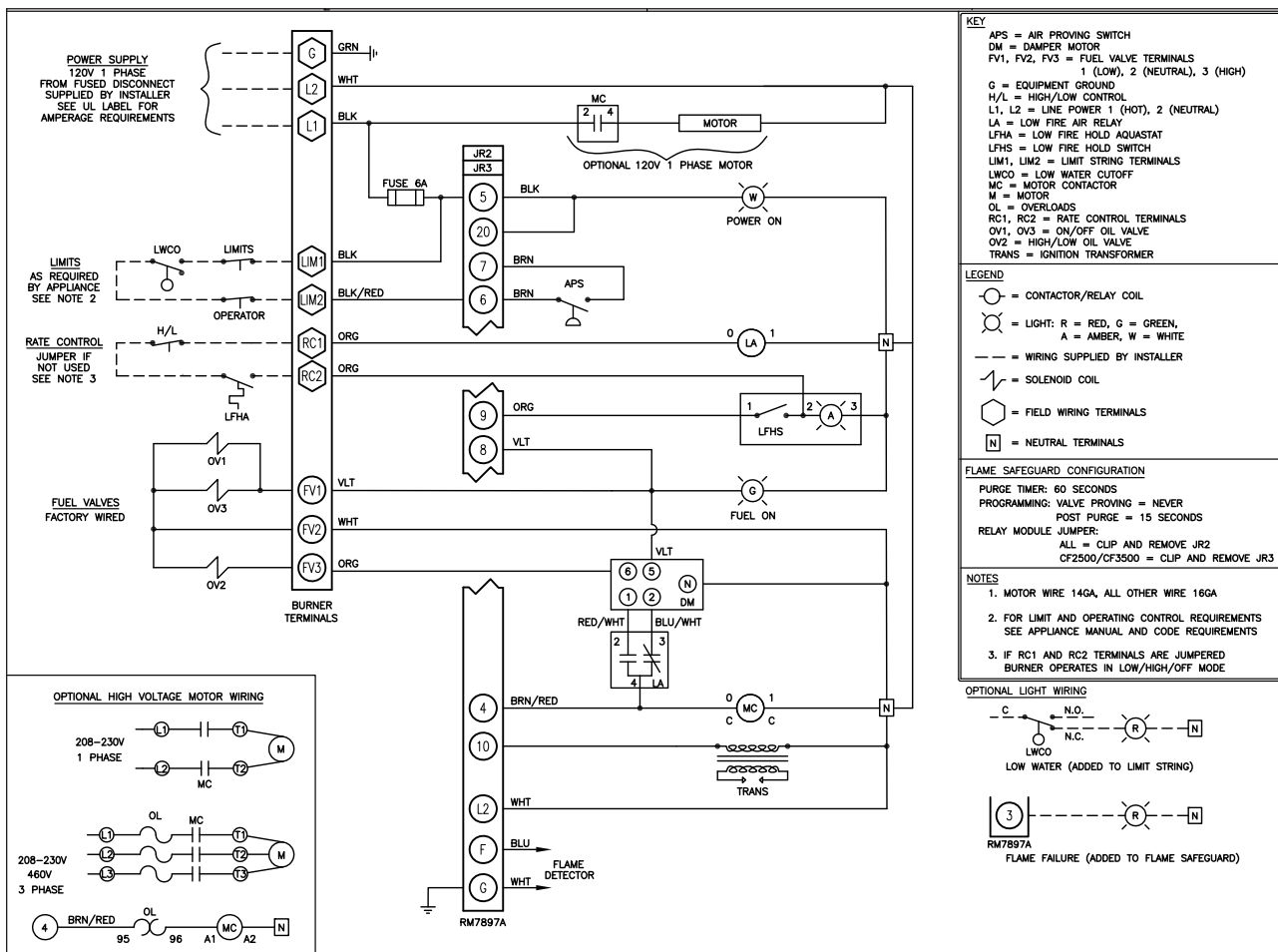

Figure 15 – Typical Wiring (RM7897A)



Prepare the Burner for Start-up

WARNING Professional Installation and Service Required

Incorrect installation and mishandling of start-up could lead to equipment malfunction and result in asphyxiation, explosion or fire.

- This burner must be installed and prepared for start-up by a qualified service technician who is trained and experienced in commercial oil burner system installation and operation.
- Do not attempt to start the burner unless you are fully qualified.
- Do not continue with this procedure until all items in the “Prepare the Burner for Start-up” section have been verified.
- Carefully follow the wiring diagrams, control instruction sheets, flame safeguard sequence of operation, test procedures and all appliance manufacturer’s directions that pertain to this installation.
- If any of these items are not clear or are unavailable, call Beckett at 1-800-645-2876 for assistance.

WARNING Do Not Bypass Safety Controls

Tampering with, or bypassing safety controls could lead to equipment malfunction and result in asphyxiation, explosion or fire.

- Safety controls are designed and installed to provide protection.
- Do not tamper with, or bypass any safety control.
- If a safety control is not functioning properly, shut off all main electrical power and fuel supply to the burner and call a qualified service agency immediately.

CAUTION Keep Service Access Covers Securely Installed

These covers must be securely in place to prevent electrical shock, damage from external elements, and protect against injury from moving parts.

- All covers or service access plates must be in place at all times except during maintenance and service.
- This applies to all controls, panels, enclosures, switches, and guards or any component with a cover as part of its design.

Start-up Checklist – Verify the following before attempting to start burner.

- Combustion air supply and venting have been inspected and verified to be free of obstructions and installed in accordance with all applicable codes.
- Oil nozzle has been selected correctly and securely installed in the nozzle adapter.
- Fuel unit by-pass plug **has not** been installed for one-pipe oil system without a by-pass loop. Refer to **Figure 9**.
- By-pass plug **has been** installed for two-pipe oil system.
- Fuel connection to nozzle line assembly is secure.
- **Dimension Z** has been set per the ‘Set Z Dimension’ instructions detailed earlier in this manual. The top acorn nut (**Figure 16**, item **d**) should never be loosened once the Z dimension is initially set.
- Fuel supply line is correctly installed, the oil tank is sufficiently filled, and shut-off valves are open.
- Burner is securely mounted in appliance, with pressure firing plate and gasket installed for pressurized chamber application.
- Appliance has been filled with water (boilers) and controls have been operationally checked.
- Burner has been installed in accordance with appliance manufacturer’s instructions (when available).
- Also refer to appliance manufacturer’s instructions (when available) for start-up procedures.

Figure 16 – Adjusting Plate Initial Setting, Typical

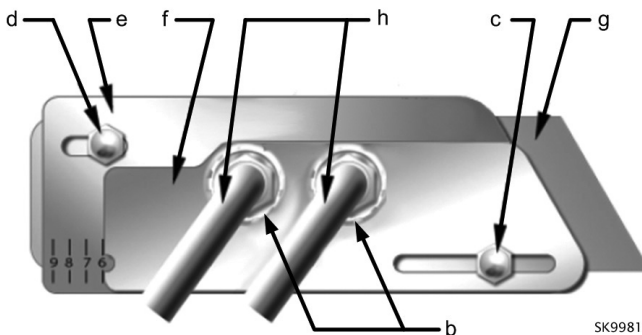

Legend

- b** Spline nut for securing nozzle line
- c** Bottom acorn nut (for head adjustments)
- d** Top acorn nut (for setting dim. Z only - do not loosen after setting Z)
- e** Indicator adjusting plate
- f** Secondary adjusting plate
- g** Primary adjusting plate
- h** Copper oil line from oil valve to nozzle line

Z Dimension

The Z Dimension should be set per the instructions detailed under the heading ‘Set Z Dimension’ previously in this manual. The top acorn nut (**Figure 16**, item **d**) should never be loosened once the Z dimension has initially been set.

Adjusting Plate Assembly

Make sure spline nut (item **b**) and bottom acorn nut (item **c**) are loose before proceeding to next section (**Figure 16**).

Initial Head Position

The indicator plate assembly (item **e**) markings correspond to head position settings (**Figure 16**).

- Slide the secondary adjusting plate (item **f**) toward the rear of the burner until the number on the indicator plate corresponds to the initial head setting given in **Table 6** for the desired firing rate and burner (high-fire).
- **Figure 16** shows a typical example, with a 6 head setting. When the head position has been set, tighten the bottom acorn nut (item **c**) and the spline nut (item **b**).

Table 6. Initial Indicator Adjustment Plate Settings for Head & Damper

Tube	Head Position		Damper Position	
	Approximate Head Setting	Firing Rate (gph)	Approximate Air Damper Setting	Firing Rate (gph)
KP (CF2500A / CF2500)	0	--	0	--
	1	--	10	8.00
	2	--	20	9.00
	3	17.00	30	11.00
	4	17.50	40	12.00
	5	18.00	50	15.00
	6	18.50	60	17.00
	7	19.00	70	18.00
	8	20.00	80	19.00
	9	21.00	90	20.00
	10	25.00	100	22.00
	--	--	105	25.00
KM / KR (CF3500A)	0	--	00	--
	1	17.00	10	8.00
	2	17.50	20	9.00
	3	18.00	30	11.00
	4	18.50	40	12.00
	5	19.00	50	15.00
	6	20.00	60	17.00
	7	21.00	70	19.00
	8	28.00	80	22.00
	9	32.00	90	25.00
	10	35.00	100	29.00
	--	--	105	35.00

Initial Air Settings

If your burner was built for a specific OEM application, the “Mfr’s Settings” label (see **Figure 1**) will indicate the application and the initial air settings made at Beckett. Please verify those settings using the following procedure.

If your burner was not built for a specified application, the following steps outline the procedure for initially setting the damper (these settings may be different from settings specific to a particular OEM).

Refer to **Figure 17A/B** and **Table 4** for this procedure.

1. Remove the cover screw (**A**) then the cover (**B**) and set aside.
2. Push in on pin (**G**) to disengage the motor from the damper shaft and cam stack. Rotate the damper shaft by hand to place the adjustment cams in a position where their adjustment scale can be easily seen. Release pin (**G**) to secure the damper shaft and cam stack to the motor.
3. Using the wrench (**C**) supplied with the damper motor, adjust the blue low fire cam (**D**) to the initial setting listed in **Table 6**.
4. Using the same wrench, adjust the red high fire cam (**H**) to the initial settings listed in **Table 6**.
5. To adjust the high fire transition, use a small straight edge screwdriver. Turn the white adjustment screw located in the orange transition cam (**J**) until the cam indicator is half way between the high and low settings on the scale.
6. After setting all the cams, make sure the damper shaft and cam stack is set between its low fire setting and its high fire setting. (If you don’t it may not move when it is powered.) Push in pin (**G**), move the damper by hand so that notch (**E**) is between the low fire setting and high fire setting on scale (**F**), then release pin (**G**) to re-engage the motor. When the motor is powered it will go to its low fire setting.

This initial setting should be adequate for starting the burner at low fire. Once the burner is in operation, the air setting will be adjusted for best performance as discussed later in this manual. Don’t forget to re-install the cover after all adjustments have been made.

NOTICE The damper plate is attached by screws to its shaft, and bears against a flat on the shaft for alignment. The shaft is secured to the damper motor by a sleeve coupling with two setscrews bearing against the damper shaft and two more against the motor shaft. The motor shaft has a flat matching the one on the damper shaft. The flats on the damper shaft and the motor shaft should be aligned so that the position indicator in the damper motor reads accurately. The best way to align the flats is to tighten the setscrews that bear against the flats on the shafts

first, and then tighten the ones that bear against the round surface of the shafts afterward.

The test for proper alignment is to disengage the damper motor from its shaft using the disengaging pin (Item **G** in **Figure 17B**) and rotate the damper plate to its full closed position. The position indicator should point to 0° within + 5° tolerance.

Figure 17A - Damper Motor with Cover



Figure 17B - Damper Motor

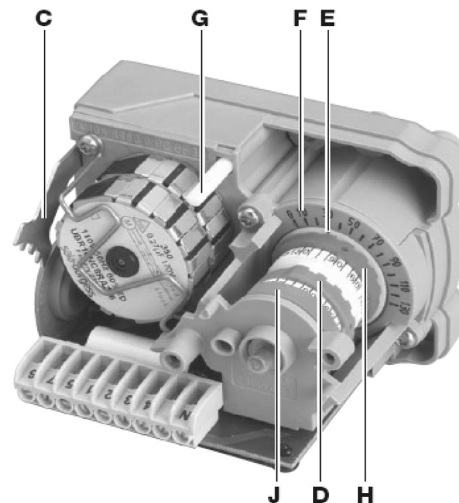

Legend (Figures 17A & 17B)

- A** Cover screw
- B** Cover
- C** Wrench
- D** Low fire cam (blue)
- E** Cam notch
- F** Damper motor scale
- G** Disengaging pin
- H** High fire cam (red)
- J** Transition cam (orange)

Set Appliance Limit Controls

- Set the appliance limit controls in accordance with the appliance manufacturer's recommendations.
- Move the low-fire hold switch (not shown) to the low fire hold position. This will hold the burner in low fire during initial start-up.

Prepare the Fuel Unit for Air Venting

1. To vent air from one-pipe oil systems, attach a clear hose to the pump bleed port (item **p** in **Figures 9 & 10**) on the fuel unit. Provide a container to catch the oil. Loosen the pump bleed port.
2. Vent the air as described in the 'Start the Burner' Section.

Start the Burner

Professional Service Required



Incorrect installation, adjustment, and use of this burner could result in severe personal injury, death, or substantial property damage from fire, carbon monoxide poisoning, soot or explosion.

Please read and understand the manual supplied with this equipment. This equipment must be installed, adjusted and put into operation only by a qualified individual or service agency that is:

- Licensed or certified to install and provide technical service to oil heating systems.
- Experienced with all applicable codes, standards and ordinances.
- Responsible for the correct installation and commission of this equipment.
- Skilled in the adjustment of oil burners using combustion test instruments.

The installation must strictly comply with all applicable codes, authorities having jurisdiction and the latest revision of the National Fire Protection Association Standard for the installation of Oil-burning Equipment, NFPA 31 (or CSA B139 and B140 in Canada).

Regulation by these authorities take precedence over the general instructions provided in this installation manual.

Do not proceed unless all prior steps in this manual have been completed.

WARNING Explosion and Fire Hazard



Failure to follow these instructions could lead to equipment malfunction and result in heavy smoke emission, soot-up, hot gas puff-back, fire and asphyxiation hazards.

- Do not attempt to start the burner when excess oil has accumulated in the appliance, the appliance is full of vapor, or when the combustion chamber is very hot.
- Do not attempt to re-establish flame with the burner running if the flame becomes extinguished during start-up, venting, or adjustment.
- **Vapor-Filled Appliance:** Allow the unit to cool off and all vapors to dissipate before attempting another start.
- **Oil-Flooded Appliance:** Shut off the electrical power and the oil supply to the burner and then clear all accumulated oil before continuing.
- If the condition still appears unsafe, contact the Fire Department. Carefully follow their directions.
- Keep a fire extinguisher nearby and ready for use.

Start Burner and Vent Air from Oil Line

WARNING Hot Gas Puff-back and Heavy Smoke Hazard

Failure to bleed the pump properly could result in unstable combustion, hot gas puff-back and heavy smoke.

- Do not allow oil to intermittently spray into a hot combustion chamber while bleeding.
- Install a gauge in the nozzle discharge port tubing or fully open the pump bleed valve to prevent oil spray from accumulating in the combustion chamber when venting air from the fuel pump.
- Ensure that all bubbles and froth are purged from the oil supply system before tightening the pump air bleed valve.

1. Move the **low-fire hold** switch to the **low fire hold** position (to hold burner in low fire when started).
2. Verify that the air adjusting cam (**Figure 17B**, item **d**) has been set to the initial low-fire air setting as described in the 'Initial Air Settings' Section.
3. Open the oil shutoff valves in the oil supply line to the burner.
4. Set the thermostat (or operating control) to call for heat.
5. Close the line switch to the burner. The burner motor should start immediately.

6. If the burner motor does not start, reset the motor overload switch (if so equipped) and press the reset switch of the burner primary control.
7. Vent the fuel unit as soon as the burner motor starts rotating. To vent —
 - o Attach a clear plastic tube to the air bleed valve (**Figure 9 or 10 as applies, item p**).
 - o Place the end of the tube in a container to catch the oil. Then loosen the fuel unit air vent valve.
 - o Tighten the air vent valve after all air has been purged.
 - o **IF burner stops during venting** —
 - The burner primary control will lockout if flame is not established within its time limit. This is typically 15 seconds for 7505 primary controls, but may be less for other flame supervisory controls.
 - The burner may lockout several times during the period needed to purge all the air. To extend air venting time, press the red reset button for 1/2 second during the prepurge cycle to continue purging with 7505 controls.
 - o **IF burner stops after flame established** —
 - Additional venting is probably required. Repeat the air venting procedure.
8. Once flame is steady, proceed to the 'Set High-fire Air' Section air.

Set High-fire Air

1. Allow the burner to run at **low fire** until the appliance has warmed sufficiently.
2. Visually check the flame. The flame should not be dark orange or smoky. If the flame appears to be smoking, increase the amount of air by readjusting the damper indicator to a higher number.
3. Once the appliance has warmed, the **high-fire** setting can be checked and adjusted.
4. Locate the approximate air adjusting plate setting for **high fire** in **Table 4**.
5. Place the **low-fire hold** switch in the **high-fire position**. The damper motor will begin to rotate after four seconds.
6. Use combustion test instruments to adjust the burner.
 - a. Adjust the air by moving the red cam to a lower number until a trace of smoke is achieved with CO₂ level as high as possible (lowest possible O₂).
Example: 13.5% CO₂ (2.5% O₂) with a trace of smoke.
 - b. Increase the air by increasing the red cam

number to reduce CO₂ by 2 percentage points at a zero smoke level. (Increase O₂ by 3 percentage points at a zero smoke level.)

Example: Reduce CO₂ from 13.5% to 11.5%, with zero smoke (or increase O₂ from 2.5% to 5.5%).

- c. A margin of reserve air has been added to accommodate variable conditions.
7. Check the breech draft pressure against the appliance manufacturer's recommended setting (typically + 0.1" W.C.).
8. If the breech pressure is higher or lower than recommended level, adjust the appliance breech damper to achieve the specified setting. Recheck the smoke and CO₂ (or O₂) levels. Adjust burner air if necessary.
9. Once all settings are complete and satisfactory, proceed to 'Set Low-fire Air' Section.

Set Low-fire Air

1. Move the **low-fire hold** switch from the **high fire position** to the **low fire hold** position.
 - a. The damper will return to the **low-fire** air setting.
2. Check the smoke and CO₂ (O₂) levels.
 - a. Pull a smoke sample from the flue.
 - b. The sample should be clean (zero smoke level).
 - c. Check the CO₂ (O₂) level:
 - d. CO₂ should be at 11 to 12% (O₂ at 5.9 to 4.5%).
 - e. If the CO₂ is less than 11% (O₂ more than 5.9%), decrease the air and check the smoke level.
3. Operate the burner from **low fire** to **high fire** and back to verify operation.
4. Turn the burner off. Wait one or two minutes (for chamber to clear) and then turn on again to verify starting characteristics.
5. Perform limit circuit performance test specified by appliance manufacturer to verify operation of burner/appliance combination.

Perform Regular Maintenance



Annual Professional Service Required



Tampering with or making incorrect adjustments could lead to equipment malfunction and result in asphyxiation, explosion or fire.

- Do not tamper with the burner or controls or make any adjustments unless you are a trained and qualified service technician.
- To ensure continued reliable operation, a qualified service technician must service this burner annually.
- More frequent service intervals may be required in dusty or adverse environments.
- Operation and adjustment of the burner requires technical training and skillful use of combustion test instruments and other test equipment.

Annual Service — by qualified service technician

- Replace the oil supply line filter. The line filter cartridge must be replaced to avoid contamination of the fuel unit and nozzle.
- Inspect the oil supply system. All fittings should be leak-tight. The supply lines should be free of water, sludge, and other restrictions.
- Remove and clean the pump strainer if applicable.
- Replace both nozzles with the specified brand, pattern, gph, flow rate, and spray angle specified by the appliance manufacturer.
- Clean and inspect the electrodes for damage, replacing any that are cracked or chipped.
- Check electrode tip settings. Replace electrodes if tips are rounded.
- Inspect the igniter spring contacts.
- Clean the cad cell lens or other sensor surface, if necessary.
- Inspect all gaskets. Replace any that are damaged or would fail to seal adequately.

- Inspect the combustion head and air tube. Remove any carbon or foreign matter. Replace all damaged units with exact parts.
- Clean the blower wheel, air inlet, air guide, burner housing, and static plate of any lint or foreign material.
- If motor is not permanently lubricated, oil motor with a few drops of SAE 20 nondetergent oil at each oil hole. DO NOT over oil motor. Excessive oiling can cause motor failure.
- Check motor current. The amp draw should not exceed the nameplate rating.
- Check all wiring for secure connections or insulation breaks.
- Check the pump pressure and cutoff function.
- Check primary control safety lockout timing.
- Check ignition system for proper operation.
- Inspect the vent system and chimney for soot accumulation or other restriction.
- Clean all flue passages and flue pipe. Replace corroded or damaged pipes.
- Clean the appliance thoroughly according to the manufacturer's recommendations.
- Check the burner performance. Refer to the section 'Set High-fire Air'.
- It is good practice to make a record of the service performed and the combustion test results.

Monthly Maintenance — by owner

- Observe combustion air openings and vent system for integrity. Openings must be clean and free of obstructions.
- Check oil lines and fittings to verify there are no leaks.
- Observe burner ignition and performance to verify smooth operation.
- Shut the system down if you observe abnormal or questionable operation. Call a qualified service agency for professional inspection and service.

Replacement Parts

For best performance specify genuine *Beckett* replacement parts

Item	Description	Description	CF2500 Part No.	CF3500 Part No.
1	Oil Valve	Mounted on Junction Box	21789U	21789U
2	Knurled Nut	All Models	3666	3666
3	Adjusting Plate Assembly	w/ Stamped Sheet Metal Door	5201703U	5201703U
4	Fuel Pump	J4PA-C10506	21529U	21529U
5	Damper Motor	2 Stage	750601U	750601U
6	Fuel Lines	Specify Length	-	-
7	Timer	Nozzle Valve Delay	21295U	21295U
8	Air Proving Switch	4" W.C.	22182U	22182U
9	Transformer	12,000 Volts	51214	51214
10	Control	Refer to UL Label for Model Numbers		
11	Pedestal Kit	All Models	31346	31346
12	Coupling Hole Plug	Use with Threaded Holes	32439U	32439U
13	Rear Cover Door Assembly	w/ Cast Aluminum Door	5994U	51204U
		w/ Stamped Sheet Metal Door	5201301U	5201302U
14	Sight Glass	All Models	31346	31346
15	Head Assembly	KP/KM	51475P	51475P
		KR	-	51637P
16	Electrode Assembly	All Models	51212	51212
17	Ignition Leads	9-1/4" Long	5990092	5990092
		10-1/2" Long	5990104	5990104
		12-3/4" Long	5990126	5990126
		16-1/4" Long	5990162	5990162
		20-1/4" Long	5990202	5990202
18	Air Tube	Refer to Figure 2		
19	Nozzel Line Assembly	Refer to Figure 5		
20	Coupling	H Pump	21514	21514
21	Blower Wheel	8.25" X 4.18"	21528U	21528U
22	Mounting Flange		31449U	31449U
23	Motor	120/208-230 Single Phase	21527U	21527U
		208-230/460 Three Phase	21547U	21547U
		575 Three Phase	21733U	21733U
	Motor Relay (Not Shown)	120V Single Phase	752804	752804
		208V Single Phase	7300	7300
		Three Phase	2194301	2194301
	Adjustable Flange	Refer to Figure 19		

Figure 18 - Burner Replacement Parts

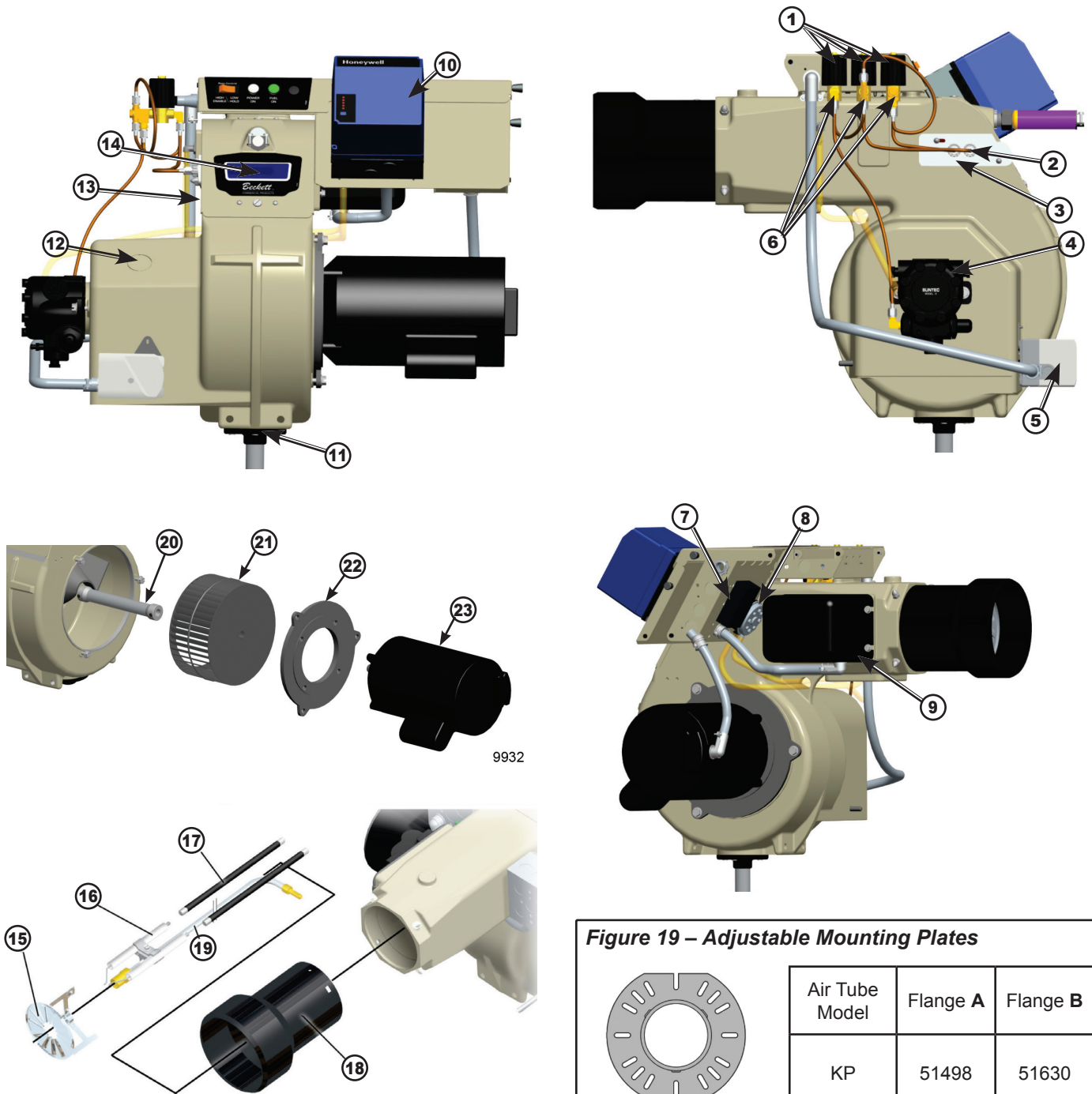

Figure 19 – Adjustable Mounting Plates

Air Tube Model	Flange A	Flange B
KP	51498	51630
KM	51498	51630
KR	N/A	51631

Limited Warranty Information

The R. W. BECKETT CORPORATION (“Beckett”) warrants to persons who purchase its “Products” from Beckett for resale, or for incorporation into a product for resale (“Customers”), that its equipment is free from defects in material and workmanship. To qualify for warranty benefits, products must be installed by a qualified service agency in full compliance with all codes and authorities having jurisdiction, and used within the tolerances of Beckett’s defined product specifications.

To review the complete warranty policy and duration of coverage for a specific product, or obtain a written copy of warranty form 61545, please choose one of the following options:

1. Visit our website at: www.beckettcorp.com/warranty
2. Email your request to: rwb-customer-service@beckettcorp.com
3. Write to: R. W. Beckett Corporation, P. O. Box 1289, Elyria, OH 44036

NOTE: Beckett is not responsible for any labor cost for removal and replacement of equipment.

THIS WARRANTY IS LIMITED TO THE PRECISE TERMS SET FORTH ABOVE, AND PROVIDES EXCLUSIVE REMEDIES EXPRESSLY IN LIEU OF ALL OTHER REMEDIES, AND IN PARTICULAR THERE SHALL BE EXCLUDED THE IMPLIED WARRANTIES OF MERCHANTABILITY AND FITNESS FOR A PARTICULAR PURPOSE. IN NO EVENT WILL BECKETT BE LIABLE FOR ANY INCIDENTAL OR CONSEQUENTIAL DAMAGE OF ANY NATURE. Beckett neither assumes, nor authorizes any person to assume for Beckett, any other liability or obligation in connection with the sale of this equipment. Beckett’s liability and Customer’s exclusive remedy is limited to the cost of the product.



USA: P.O. Box 1289 • Elyria, Ohio 44036

Canada: R.W. Beckett Canada, Ltd. • Unit #3, 430 Laird Road • Guelph, Ontario N1G 3X7
www.beckettcorp.com