

AquaSmart Boiler Temperature Control

How Does a Traditional Boiler Temperature Control Operate

The boiler temperature control acts as a limit switch. It is the central link for burner and circulator operation. The boiler temperature control has adjustable temperature sensing for limit control, which will be made to address different applications. The limit switch can be made to open on temperature rise and/or open or close on temperature fall. There are three common types of boiler temperature controls (See Figure B) that provide single acting, dual acting and triple acting functions.

Single Acting Boiler Temperature Control (See Figure A)

A Single Acting Boiler Temperature Control will incorporate a high limit function that basically acts like an on – off switch. The high limit setting is the maximum temperature the boiler can attain. When the high limit set point is reached the burner turns off. The high limit differential setting is approximately 10° less than the high limit setting. When the high limit differential set point is reached the control closes, allowing the burner to turn back on if there is still a call for heat.

The low limit setting is the minimum temperature the boiler can attain. When the low limit set point is reached the burner turns on. The low limit differential setting is approximately 10° higher than the low limit setting. When the low limit differential set point is reached. The burner turns off as long as there is no call for heat

You can control both high and low limits using two single acting boiler temperature controls, one set for high limit and one set for low limit.

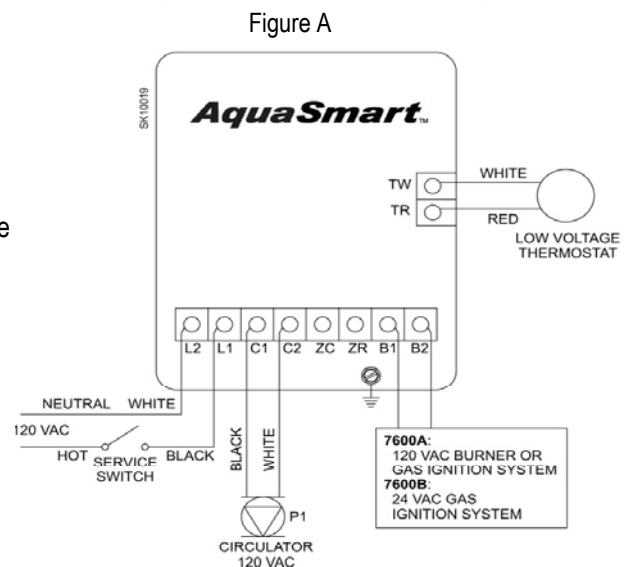

Dual Acting Boiler Temperature Control

A Dual Acting Boiler Temperature Control will incorporate a high limit/differential function along with controlling the circulator. The high limit/differential functions are identical to the description given for the Single Acting Boiler Temperature Control.

Additionally the Dual Acting Boiler Temperature Control will employ circulator terminals that energize a circulator to distribute heat transfer fluid to the heated zone. The thermostat controls the circulator, turning it on and off as dictated by sensed temperatures in the heated space. The boiler temperature control opens to turn the circulator off if boiler water temperature drops below the low limit to maintain a minimum boiler temperature.

Triple Acting Boiler Temperature Control

A Triple Acting Boiler Temperature Control incorporates a high and low limit with differential functions, along with a relay to energize the circulator. The high and low limit functions are identical to the description given for the Single Acting Boiler Temperature Control. The low limit maintains a minimum temperature while the high limit controls maximum temperature.

The Triple Acting Boiler Temperature Control also controls circulator functions. The circulator circulates the heat transfer fluid to the heated zone. As with the Dual Acting Boiler Temperature Control, the circulator turns on and off by thermostat input. The boiler temperature control opens to turn the circulator off if boiler water temperature drops below the low limit to maintain a minimum boiler temperature.

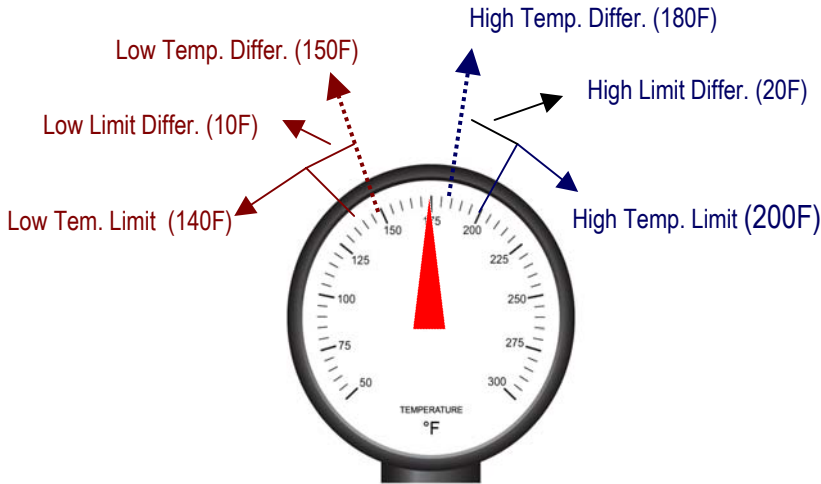

Types of Boiler Temperature Controls

BTC Type	Action
Single Acting	High or Low limit function
Dual Acting	High or Low limit function Circulator function
Triple Acting	High limit function Low limit function Circulator function

Figure B

Typical Sequence of Operation Examples

Maintaining the Low Limit

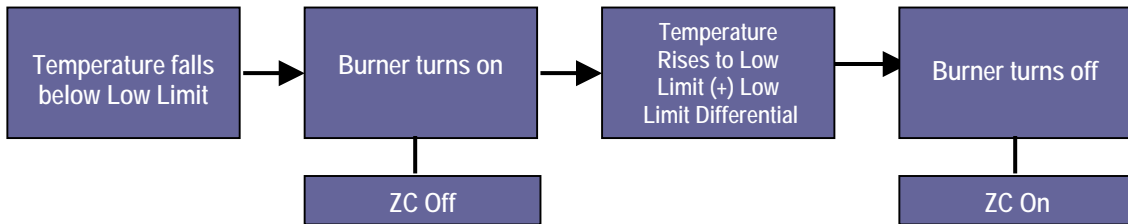

(Assumption: No TT Call for heat)

Maintaining the High Limit

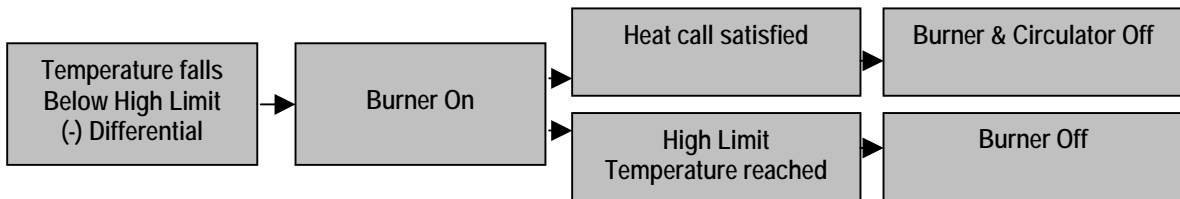

Call for Heat

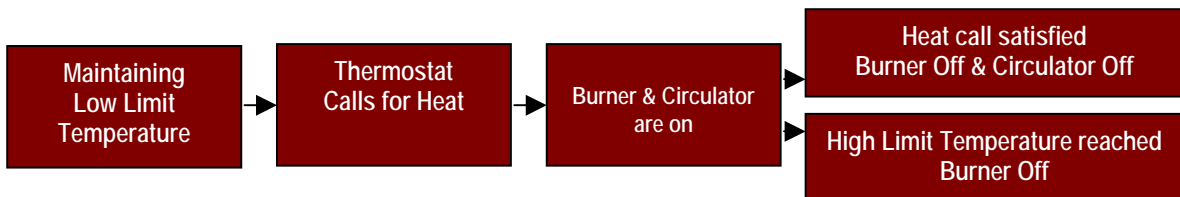

AquaSmart™: The Beckett Difference

The Beckett AquaSmart is an advanced triple acting boiler temperature control designed for use on residential and light commercial boiler systems. All models include the option of enabling the Beckett HeatManager™ dynamic temperature reset that when selected provides up to 20% fuel consumption savings.

How does AquaSmart optimize fuel efficiency?

- HeatManager Calculation
The Beckett AquaSmart™ comes equipped with the HeatManager energy saving calculation. The HeatManager saves fuel by changing the temperature high operating limit to the minimum temperature necessary to meet the heating demand.
- Circulator-off delay time
The circulator continues for the delay time after the boiler stops firing, which allows for the maximum usage of latent heat in the boiler.

Both of these features are programmable by the contractor.



HeatManager™ Technology

The Beckett AquaSmart comes equipped with the Department of Energy (DOE) 2012 compliant HeatManager load-matching energy saving calculation. The HeatManager saves fuel by dynamically changing the temperature high operating limit to the minimum temperature necessary to meet the heating demand. The contractor can adjust the HeatManager calculation to maximize comfort or energy savings.

The HeatManager calculation is designed to operate the boiler at its lowest possible temperature while still meeting the heating demand. By dynamically changing the boiler temperature, it is designed to reduce the energy used by the system without sacrificing comfort.

The default *HIGH* efficiency setting should work best for most systems. However, there are many system factors that may have an effect on its ability to react to changes quickly enough and supply adequate heat, such as the amount of connected radiation, boiler size, system design temperatures, etc.

The efficiency setting adjusts how aggressively the HeatManager calculation attempts to reduce the boiler operating temperature. If a loss of comfort is experienced, decreasing the efficiency setting will help regain comfort at the expense of fuel savings.

Programming the HeatManager Setting

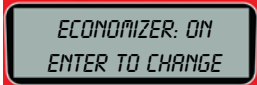
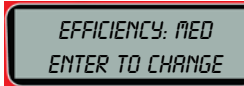
1. In any mode or screen other than an *OPTION* sub-menu, press the **"OPTION"** key.
2. The following screen will be displayed. 
3. Press the **"ENTER (RESET)"** key.
4. The following screen will be displayed. 
5. To toggle the fuel economizer on or off; Press **"ENTER (RESET)"** key.
6. To Adjust the HeatManager efficiency setting press the **"▲"** and **"▼"** keys until the  following screen is displayed.
7. Press **"ENTER (RESET)"** to toggle the comfort setting between *HIGH*, *MEDIUM*, and *LOW*.

How will the new HeatManager algorithm interact with a system utilizing a tankless coil?

The HeatManager algorithm will positively affect the hot water available in a system utilizing a tankless coil. Because the HeatManager does not change the low limit setting to accommodate the tankless coil or “hold off” the burner when it needs to fire you can expect more consistency in your hot water supply.

How will I know that the AquaSmart control has been installed correctly?

AquaSmart Control Checkout Procedure

These procedures are typical for the default configuration of the control. Before beginning the AquaSmart checkout procedures make sure the control is wired and configured as is required by the application.

	<i>Contractor Action</i>	<i>During this step: Control Activity</i>		<i>During this step: Display</i>	<i>During this step: Should Be</i>
<i>Step 1</i>	Apply a non-TT call for heat	Burner turns on	Burner heats water above the low limit + low diff.	“HEATING WTR”	Burner (B1) – on Circulator (C1) – off Zone Control (ZC) - off
<i>Step 2</i>		Water is sufficiently heated (Temp. above low limit + low diff.) Burner turns off and zone control is energized.		“STANDBY”	Burner (B1) – off Circulator (C1) – off Zone Control (ZC) - on
<i>Step 3</i>	Apply a call for heat from the thermostat	Burner and circulator should turn on		“HEATING WTR” or “HEATING DHW”	Burner (B1) – on Circulator (C1) – on Zone Control (ZC) - on
<i>Step 4</i>		AquaSmart heats Water to high limit. When high limit is reached the burner turns off		“CIRCULATING”	Burner (B1) – off Circulator (C1) – on Zone Control (ZC) - on
<i>Step 5</i>	Set thermostat back so there is no longer a call for heat	Circulator should turn off		“STANDBY”	Burner (B1) – off Circulator (C1) – off Zone Control (ZC) - on

CAUTION! Do not leave the installation site if the AquaSmart operation did not match the descriptions in any of the above steps. Make all necessary adjustments until the correct operation is verified. The above procedure helps to verify that the high and low limits are working properly and that the thermostat is wired correctly to the control.